



Health  
Canada

Santé  
Canada

March 17, 2008

## Notice

### **Publication of Final Guidance Document - Adult Hospital Beds: Patient Entrapment Hazards, Side Rail Latching Reliability, and Other Hazards**

Our file number: 08-107422-917

Health Canada is pleased to announce the publication of the final Guidance Document *Adult Hospital Beds: Patient Entrapment Hazards, Side Rail Latching Reliability, and Other Hazards*. A draft of this Guidance Document was posted for comment on April 30, 2006, with a comment period ending July 3, 2007. The final Guidance Document has been amended to address questions and comments received.

This Guidance Document is intended to assist manufacturers in understanding and complying with the regulatory requirements of sections 10-21 of the *Medical Devices Regulations* as they pertain to the design and directions for use for hospital beds. It is based on the US FDA Guidance entitled *Hospital Bed System Dimensional and Assessment Guidance to Reduce Entrapment*, published March 10, 2006, which was developed by a working group on which the Medical Devices Bureau of Health Canada participated.

In addition, the Guidance Document provides recommendations to assist health care facilities in assessing side rail latching reliability and other potential hazards.

This Guidance Document is available in both French and English on the Health Canada website.

Comments or question regarding this Guidance Document should be directed to:

Medical Devices Bureau  
Therapeutic Products Directorate  
Health Canada  
2934 Baseline Road, Tower B  
Address Locator: 3403A  
OTTAWA, Ontario K1A 0K9  
E-mail: [mdb\\_enquiries@hc-sc.gc.ca](mailto:mdb_enquiries@hc-sc.gc.ca)  
Telephone: 613-957-4786  
Fax: 613-957-7318

Canada 



Health  
Canada

Santé  
Canada

## **GUIDANCE DOCUMENT**

### **Adult Hospital Beds: Patient Entrapment Hazards, Side Rail Latching Reliability, and Other Hazards**

Published by authority of the  
Minister of Health

Date Adopted	2006/12/20
Revised Date	2008/02/29
Effective Date	2008/03/17

**Health Products and Food Branch**

**Canada** 

<p>Our mission is to help the people of Canada maintain and improve their health.</p> <p style="text-align: right;"><i>Health Canada</i></p>	<p>HPFB's Mandate is to take an integrated approach to managing the health-related risks and benefits of health products and food by:</p> <ul style="list-style-type: none"> <li>• minimizing health risk factors to Canadians while maximizing the safety provided by the regulatory system for health products and food; and,</li> <li>• promoting conditions that enable Canadians to make healthy choices and providing information so that they can make informed decisions about their health.</li> </ul> <p style="text-align: right;"><i>Health Products and Food Branch</i></p>
--	--

© Minister of Public Works and Government Services Canada 2006

*Également disponible en français sous le titre* : Les lits d'hôpitaux pour adultes : Risque de piégeage des patients, fiabilité du verrouillage des barrières et autre risques

## FOREWORD

Guidance documents are meant to provide assistance to industry and health care professionals on **how** to comply with governing statutes and regulations. Guidance documents also provide assistance to staff on how Health Canada mandates and objectives should be implemented in a manner that is fair, consistent and effective.

Guidance documents are administrative instruments not having force of law and, as such, allow for flexibility in approach. Alternate approaches to the principles and practices described in this document *may be* acceptable provided they are supported by adequate justification. Alternate approaches should be discussed in advance with the relevant program area to avoid the possible finding that applicable statutory or regulatory requirements have not been met.

As a corollary to the above, it is equally important to note that Health Canada reserves the right to request information or material, or define conditions not specifically described in this document, in order to allow the Department to adequately assess the safety, efficacy or quality of a therapeutic product. Health Canada is committed to ensuring that such requests are justifiable and that decisions are clearly documented.

This document should be read in conjunction with the accompanying notice and the relevant sections of other applicable guidance documents.

## TABLE OF CONTENTS

1. INTRODUCTION.....	1
1.1 Policy Objectives.....	2
1.2 Policy Statements.....	2
1.3 Application.....	3
1.4 Background.....	3
1.4.1 Current Regulations, Standards, and Future Harmonization.....	5
2 GUIDANCE FOR IMPLEMENTATION.....	7
2.1 Organization of this Guidance.....	7
2.2 Detailed Scope.....	7
2.2.1 Articulation.....	9
2.2.2 Legacy Beds.....	9
2.2.3 Exclusions.....	11
2.3 Reporting Incidents.....	13
2.3.1 Reporting an Entrapment Adverse Event.....	13
2.3.2 Reporting a Side Rail Latch Failure.....	14
2.4 Key Body Parts at Risk.....	14
2.4.1 Head.....	14
2.4.2 Neck.....	15
2.4.3 Chest.....	16
2.5 Potential Zones of Entrapment.....	17
2.6 A Retrospective Study of Entrapment Reports to FDA.....	18
2.7 Dimensional Limits for Identified Entrapment Zones 1-4.....	19
2.7.1 Zone 1 – Within the Rail.....	20
2.7.2 Zone 2 - Under the Rail, Between the Rail Supports or Next to a Single Rail Support	21
2.7.3 Zone 3 - Between the Rail and the Mattress.....	22
2.7.4 Zone 4 - Under the Rail at the Ends of the Rail.....	23
2.7.5 Zone 5 – Between Split Bed Rails.....	24
2.7.6 Zone 6 - Between the End of the Rail and the Side Edge of the Headboard or	
Footboard.....	25
2.7.7 Zone 7 - Between the Headboard or Footboard and the End of the Mattress.....	26
2.7.8 Comparison of IEC Bed Standard and Health Canada Guidance.....	26
2.7.9 Entrapment Between Components of Bed System and Accessories.....	27
2.8 Side Rail Height.....	28
2.9 Side Rail Latch Reliability - Requirements and Test Methods.....	29
2.10 Mattress Compatibility Information.....	31
2.11 Other Hazards.....	32
APPENDIX A List of Hospital Bed Safety Workgroup (HBSW) Participating Organizations...	34
APPENDIX B Additional Information and Kit Information.....	36
APPENDIX C References for National and International Entrapment Standards.....	38

---

APPENDIX D Anthropometric References.....	39
APPENDIX E Drawings of Potential Entrapment in Hospital Beds.....	41
APPENDIX F Dimensional Test Methods for Bed Systems.....	42
1. Introduction.....	42
2. Summary of Test Zones.....	42
3.1 Cone and Cylinder Tool.....	44
3.2 Tool Assembly and Disassembly.....	45
3.3 Using the spring scale.....	46
4. General Testing Considerations.....	46
5. Test Methods.....	47
5.1 Zone 1 Test.....	47
5.2 Zone 2 Test.....	48
5.3 Zone 3 Test.....	51
5.4 Zone 4 Test.....	53
Appendix to HBSW Dimensional Test Methods for Bed Systems Testing Tips and Frequent Questions.....	56

## 1. INTRODUCTION

This guidance document (guidance) is intended to assist manufacturers in understanding and complying with the regulatory requirements of sections 10-21 of the *Medical Devices Regulations (Regulations)* as they pertain to the design and directions for use for hospital beds. This guidance document should be used in conjunction with the *Guidance Document Recognition and Use of Standards under the Medical Devices Regulations*.

This guidance provides recommendations relating to hospital beds<sup>1</sup> and hospital bed accessories and these recommendations are intended to reduce life-threatening entrapments associated with hospital bed systems<sup>2</sup>. It characterizes the body parts at risk for entrapment, identifies the locations of hospital bed openings that are potential entrapment areas, and recommends dimensional criteria for these devices.

Additionally, this guidance makes reference to a document which provides recommendations on how to mitigate the risk posed by beds which do not meet the recommendations designed to reduce life-threatening entrapments. This document is entitled *A Guide for Modifying Bed Systems and Using Accessories to Reduce the Risk of Entrapment*, and is available as a link from the U.S. Food and Drug Administration (FDA) website.

Finally, the guidance provides recommendations on how to assess side rail latching reliability, as accidental lowering of side rails occurs frequently, either as a result of improper latching, or the latch failing.

Manufacturers may use this guidance when designing new beds to help ensure compliance with applicable *Acts and Regulations*<sup>3</sup>, to provide adequate labelling and instructions for use, and to assist in ensuring that their devices are safe when used as labelled. Health Canada encourages manufacturers to provide information to medical device distributors, clinicians, patients<sup>4</sup> and families regarding mattress dimensions, compatible components, and issues of entrapment. In addition, the recommendations in this guidance may be useful in evaluating and reducing the entrapment risk presented by hospital beds that have been placed into use, also known as legacy beds.

---

<sup>1</sup> The terms “medical bed” and “hospital bed” are used interchangeably throughout this document and include adult medical beds with siderails. See discussion in Detailed Scope, section 2.2.

<sup>2</sup> As used in this guidance, “hospital bed system” encompasses the bed frame and its components, including the mattress, bed side rails, head and foot board, and any accessories added to the bed.

<sup>3</sup> *Food and Drugs Act, Medical Devices Regulations*.

<sup>4</sup> The term “patients” includes residents or other types of individuals that use hospital beds in a variety of health care settings.

Not all patients are at risk for an entrapment, and not all hospital beds pose a risk of entrapment. It is suggested that facilities determine the level of risk for entrapment and take steps to mitigate the risk. Additionally, the manufacturer may assist in this process during the selection of equipment for purchase (or lease) by the facility or during the equipment's lease period to the facility. Evaluating the dimensional limits of the gaps in hospital beds is one component of an overall assessment and mitigation strategy to reduce entrapment. As a result, healthcare facilities may use this guidance as part of a bed safety program to help identify entrapment risks that may exist with current hospital bed systems. Other educational documents are available to assist health care facilities in making decisions towards the goal of achieving a safe and comfortable sleeping environment for their patients.

Health Canada's guidance documents, including this guidance, do not establish legally enforceable responsibilities. Instead, guidances describe the Department's current thinking on a topic and should be viewed only as recommendations (see Foreword). The use of the word *should* in the guidance means that something is suggested or recommended, but not required.

While most beds in Canada are Class I devices and therefore not subject to licensing, they are nevertheless medical devices and subject to the requirements of the *Medical Devices Regulations*. As such, any post-market issues with beds will be evaluated by Health Canada in light of these *Regulations* and this guidance. Manufacturers are encouraged to ensure that the beds they sell in Canada, meet the recommendations set out in this guidance.

Health Canada believes the least burdensome approach in all areas of medical device regulation should be considered. This guidance reflects Health Canada's careful review of the relevant scientific and legal requirements and what the Department believes is the least burdensome way for manufacturers to comply with those requirements. However, if it is believed that an alternative approach would be less burdensome, a manufacturer may contact Health Canada to allow the Department to consider this point of view.

## **1.1 Policy Objectives**

To reduce the risks associated with the use of hospital beds by providing manufacturers with guidance on how to design and label these beds such that life-threatening patient entrapment hazards, side rail latch failures, and other hazards are minimized.

## **1.2 Policy Statements**

All manufacturers of hospital beds are expected to design and label their hospital beds to minimize a) the potential for the patient to become entrapped in a life-threatening situation, b) the potential for side rail latch failure, and c) other hazards as identified in this guidance.



This guidance provides recommendations on how to design and test beds that will present minimal entrapment or side rail latch failure hazards. Alternately, the manufacturer may provide Health Canada with evidence showing that their bed designs, through some other means, comply with the recommendations of this guidance.

### 1.3 Application

This guidance document applies to all manufacturers of hospital beds, as noted in Table 1 and as noted in the listed exceptions. See the “Detailed Scope” in section 2.2 for further detail.

### 1.4 Background

For more than 20 years, Health Canada has received reports<sup>5,6</sup> in which vulnerable patients<sup>7,8</sup> have become entrapped in hospital beds while undergoing care and treatment in health care facilities. The term "entrapment" describes an event in which a patient/resident is caught, trapped, or entangled in the space in or about the bed rail<sup>9</sup>, mattress, or hospital bed frame. Patient entrapments may result in deaths and serious injuries.

Health Canada has received, between 1980 and April 2006, 51 reported incidents of life-threatening bed entrapments in Canada, 26 of which led to deaths. Entrapment events account for almost one fifth (18.3 %) of all types of reported problems and 63% of all deaths (41) that have

---

<sup>5</sup> Health Canada Medical Devices Alert No. 107, “Hazard with Hospital Bed Split Side Rails”, August 10, 1995.

<sup>6</sup> Roy, Denis, “Beds and Side Rails: How Safe Are They?”, Dimensions in Health Service, May 1990.

<sup>7</sup> U. S. Food and Drug Administration. FDA Safety Alert: Entrapment Hazards with Hospital Bed Side Rails (August 23, 1995), U.S. Department of Health and Human Services.

<sup>8</sup> “Vulnerable patients” are defined in “A Guide to Bed Safety,” developed by the Hospital Bed Safety Workgroup (described in section 1.4), as: “Patients who have problems with memory, sleeping, incontinence, pain, uncontrolled body movement or who get out of bed and walk unsafely without assistance. These patients most often have been frail, elderly or confused.”

<sup>9</sup> Health Canada uses the term “bed rails” frequently throughout this document. Commonly used synonymous terms are side rails, bed side rails, grab bars and safety rails. Bed rails are rigid bars that are attached to the bed and are available in a variety of sizes and configurations from full length to half, one-quarter, and one-eighth length and are used as restraints, reminders, or as assistive devices. Additionally they help prevent the patient from rolling or falling out of bed when unattended. An historical review can be found in Braun & Capezuti, “The Legal and Medical Aspects of Physical Restraints and Bed Side rails and Their Relationship to Falls and Fall-Related Injuries in Nursing Homes,” DePaul Journal of Health Care Law, vol. 4, Fall 2000.

been reported with the use of beds. There have been at least 17 coroners' inquests or investigations into deaths related to beds and side rails; many of these deaths are included in the above statistics. Additionally, there have been nearly as many incidents related to side rail latch failures.

There is an incident reported almost every 3 months in Canada where a patient entrapment or rail latch failure occurs. Since device incidents generally tend to be under-reported, the number of actual entrapment deaths or rail latch failures could be much higher. Most of these might have been prevented with improved bed and side rail designs.

In the United States, the U.S. Food and Drug Administration (FDA) has, for its part, received approximately 691 entrapment reports over a period of 21 years from January 1, 1985, to January 1, 2006<sup>10</sup>. In these reports, 413 people died, 120 were injured, and 158 were near-miss events with no serious injury as a result of intervention.

Despite many published articles on the inherent risks posed by these devices, there has not been a marked reduction of incidents over the years.

These entrapment events have occurred in openings within the bed rails, between the bed rails and mattresses, under bed rails, between split rails, and between the bed rails and headboard or footboard. The population most vulnerable to entrapment are elderly patients and residents, especially those who are frail, confused, restless, or who have uncontrolled body movement. Entrapments have occurred in a variety of patient care settings, including hospitals, nursing homes, and private homes. Long-term care facilities reported the majority of the entrapments.

In response to continued reports of patient entrapment, the FDA, in partnership with the U.S. Department of Veterans Affairs, Health Canada's Medical Devices Bureau, and representatives from national health care organizations and provider groups, patient advocacy groups, and medical bed and equipment manufacturers, formed a working group in 1999 known as the Hospital Bed Safety Workgroup (HBSW). Appendix A contains a list of HBSW participating organizations. The HBSW also worked in cooperation with the Joint Commission on Accreditation of Healthcare Organizations, the U.S. Centers for Medicare and Medicaid Services, and the U.S. Consumer Product Safety Commission to improve patient safety associated with the use of hospital beds.

---

<sup>10</sup> FDA acknowledges several limitations of these adverse event report data. First, many adverse events may not be reported to the FDA, thus the true number of adverse events may be unknown. Second, the number of reported events does not represent incident rates for a given problem in the absence of a defined denominator - the number of individuals at risk for a given adverse event. Finally, many reports lack a complete and detailed description of the adverse event or are not verified. Despite these limitations, adverse event reports can suggest a profile of the areas or locations on a hospital bed that present a risk of entrapment, as well as the parts of the body that are at risk of entrapment.

The HBSW identified seven potential entrapment zones (see Potential Zones of Entrapment, section 2.5) in hospital beds. The workgroup then developed (1) educational materials regarding entrapment associated with hospital beds, (2) clinical practice guidelines to reduce the occurrence of patient entrapment, (3) evidence-based dimensional guidelines for hospital beds, (4) test tools and methods to assess gaps in hospital bed systems, and (5) information to assist in mitigating entrapment risks in currently used hospital beds. See Appendix B for information on the availability of these materials.

Item (1), entitled *A Guide to Bed Safety; Bed Rails in Hospitals, Nursing Homes and Home Health Care* can be downloaded from Health Canada's website.

Item (2), entitled *Clinical Guidance for the Assessment and Implementation of Bed Rails in Hospitals, Long Term Care Facilities, and Home Care Settings* is available as a link from the U.S. FDA website.

Items (3) and (4) are part of this guidance.

Item (5) can be used by both manufacturers and users wishing to bring legacy beds into compliance with the guidance, but it is a document probably of most use to users. It is entitled *A Guide for Modifying Bed Systems and Using Accessories to Reduce the Risk of Entrapment*, and is available as a link from the U.S. FDA website.

The HBSW submitted to FDA recommendations for hospital bed dimensional criteria for consideration as an FDA guidance document. Members of the HBSW developed, as noted above, procedures for measuring and assessing gaps in hospital bed systems in accordance with these criteria. Healthcare personnel, through participation in HBSW testing, validated the test methods and tools. The FDA considered these HBSW recommendations in preparing its own guidance (which is available as a link from the U.S. FDA website), as did Health Canada in the preparation of this guidance.

#### ***1.4.1 Current Regulations, Standards, and Future Harmonization***

Under the Canadian *Medical Devices Regulations*, most beds are classified as Class I devices. Class I medical devices do not require a medical device licence and, therefore, there is no pre-market review by Health Canada. However, Class I devices must comply with the safety and effectiveness requirements contained in ss 9-23 and s 25. Some specialty beds are Class II (e.g., powered patient rotation beds, and powered flotation therapy beds), and a few are Class III (e.g., breathing assist rocking beds) but the vast majority fall within Class I. The Therapeutic Products Directorate (TPD) does not review safety data or instructions for use of most Class II devices. There are no criteria to adequately review the design for hospital beds. At present, there are no national standards or regulations specific to beds or side rails in either Canada or the United States.

The International Electrotechnical Commission (IEC) issued an internationally recognized standard that applies to a certain segment of the products addressed in this guidance, products labelled as “electrically-operated hospital beds.” This standard is IEC 60601-2-38, including Amendment 1<sup>11</sup>. The current IEC standard recognizes that the bed frame, deck, and rails are the major elements involved in entrapment, but does not include the mattress as a contributor or mitigator and sets dimensions for new beds only. The standard also does not address safety issues associated with the use of non-electric hospital beds or the use of hospital beds in the home or in long-term care settings. The IEC standard is currently undergoing revision and will likely undergo significant change prior to its expected publication in 2007/2008. The recommendations in this guidance are similar to the IEC standard for some entrapment zones, but differ in other zones to include consideration of the mattress as part of the system used to mitigate entrapment risk or in some cases as part of the entrapment risk itself. The IEC test methods are not readily applicable for use by health care providers and are written primarily for test labs while the test methods in this guidance can be used by both manufacturers and health care providers; the latter would use them to assess whether older beds meet and continue to meet the guidance’s recommendations. Upon completion of the revised international bed standard, FDA and Health Canada will consider whether harmonization of their respective guidances and the IEC standard is appropriate. See Appendix C for a list of national and international entrapment standards.

In addition to entrapment issues, many reported incidents with beds involve the failure of the side rail latching mechanism, which can lead to the patients falling out of the bed, or entrapment if part of the body is located near the rail at the time of the latch failure. Health Canada’s position on this issue is that no rail should be designed in such a way that it appears to have locked in place without the latch actually being securely engaged. As well, latches should be designed in such a way that they will provide a certain measure of reliability and protection from premature wear.

Finally, if the mattress is used as part of the bed’s mitigation system to reduce the frequency of entrapments, the end-user of the bed must know what the recommended dimensions for this mattress are as well as the recommended type. Too often a facility will contract a supplier for a mattress replacement program for a variety of beds, many of which may not have the same mattress size or type requirements. This has led to beds that are fitted with improperly sized mattresses or mattresses of the improper type. While the bed’s manufacturer may have provided this information in the bed’s manual or user instructions, this documentation is often misplaced, particularly if the bed is relocated elsewhere, and the manufacturer’s name or bed model number may no longer be visible

---

<sup>11</sup> International Electrotechnical Commission (IEC) 60601-2-38, 1996 and Amendment 1, 1999 Medical Electrical Equipment - Part 2-38: *Particular Requirements for the Safety of Electrically-Operated Hospital Beds*.

on the bed. In this context, it is imperative that the information about mattress compatibility be clearly and permanently marked on the bed.

## **2 GUIDANCE FOR IMPLEMENTATION**

### **2.1 Organization of this Guidance**

This guidance:

- identifies key parts of the body at risk for entrapment;
- describes potential entrapment areas or zones;
- recommends maximum and minimum dimensional limits of gaps or openings in hospital bed systems;
- provides a scientific basis for the dimensional limits derived from a review of international anthropometric data, a review of historical entrapment data, and a retrospective study to verify the proposed dimensional limits;
- provides information about reporting entrapment adverse events;
- provides a copy of the HBSW test methods for assessing gaps or openings in hospital bed systems;
- provides information about obtaining other HBSW documents and instructional materials;
- provides test methodology on how to test the reliability of side rail latches
- provides information about specifying mattress compatibility; and
- provides information about other issues identified with hospital beds.

### **2.2 Detailed Scope**

The goal of the Health Canada Guidance Document *Hospital Beds: Patient Entrapment Hazards, Side Rail Latching Reliability, and Other Hazards* is to reduce potential life-threatening entrapments associated with hospital bed systems, as well as addressing other issues such as side rail latch reliability. Since hospital bed systems that are primarily intended for one type of care setting can be moved into other care settings, the recommendations in this guidance may be appropriate for hospital beds regardless of the healthcare setting. The dimensional limits in this

guidance may not reduce entrapments in all populations, e.g. pediatrics and developmentally disabled people. See the narrative below in the exclusions section, section 2.2.3.

Health Canada uses the term “hospital bed” in this guidance to refer to a variety of medical devices that are classified as beds. Health Canada regulations classify hospital beds as Class I, Class II and Class III devices (see Table 1), but the vast majority are Class I. These devices are used for patients in acute care, long-term care, or home care settings. Health Canada considers stretchers that are used for extended stay in health care facilities (because they are used like hospital beds) as hospital beds for purposes of this guidance. As stated above, the term “hospital bed system” used throughout this document encompasses the bed frame and its components, including the mattress, bed side rails, headboard and footboard, and any accessories added to the bed.

Bed rails (see footnote 8), also called “side rails,” may be an integral part of the bed frame or they may be removable and at times are used either as a restraint, a reminder or an assistive device. Bed rails may consist of one full-length rail per side or one or more, shorter rails per side, may be a fixed height or adjustable in height, and may move as the head section or foot section of the bed is raised or lowered.

This guidance provides recommendations related to devices in the following table (Table 1). Class II and III devices are subject to device licensing and Quality Management System requirements as per the *Medical Devices Regulations*. The recommendations in this guidance will assist manufacturers of all devices listed in Table 1 below in manufacturing hospital beds that will minimize the risk for patient entrapment.

**Table 1: Bed Systems Covered under this guidance**

Preferred Name Code	Classification Name	Class
80FNJ	Manual adjustable hospital bed	I
80FNK	Hydraulic adjustable hospital bed	I
80FNL	AC-powered adjustable hospital bed	I
89IKZ	Powered patient rotation bed	II
89INY	Manual patient rotation bed	I
89IOQ	Powered flotation therapy bed	II
73CCO	Breathing assist rocking bed	III

The documents and the tools used to measure gaps were produced considering an adult population’s size and for use with beds designed for care of the adult patient. The dimensions specified to limit gaps are not appropriate to children in most cases and may not be appropriate for some adult populations, e.g. developmentally disabled people. However, the HBSW Clinical

guidance document can serve as an outline to help the manufacturer design a bed system that is suitable for the child patient insofar as entrapment risks are concerned.

The recommendations in this guidance may also be useful in evaluating and reducing the risk of entrapment presented by the devices listed in Table 1 that have already been manufactured and installed (legacy beds). Health Canada recognizes that legacy beds have the potential for dimensional change over time through wear and tear or substitution of new mattresses and other components not contemplated in the original bed system. Any changes by a manufacturer to a legacy bed's design or instructions for use in an attempt to mitigate entrapment or other risks would be subject to the recall provisions of the *Medical Devices Regulations* (see ss 63-65). Manufacturers and importers must maintain records of any corrections as per s 57 of the *Regulations*. As well, facilities should ensure that side rails, mattresses, and other components are maintained or replaced as needed and that any changes will result in the bed system continuing to meet the recommendations in this guidance. See section 2.7 for further information.

### **2.2.1 Articulation**

The movement of the bed deck is known as articulation. Health Canada recognizes that articulation of the bed introduces complex geometries that make applying the dimensional criteria to reduce entrapment difficult. Presently, the dimensional recommendations in this guidance apply to hospital beds in the flat deck position and rails in the fully raised position, except where noted. Health Canada recognizes that patient care also occurs while the bed is articulated and some articulated positions may pose a risk of entrapment. The Department will continue to gather data and consider other approaches for assessing gaps in articulated beds in the future. Health Canada recommends that patient assessment procedures be used to assess the risk of entrapment when clinical care is provided in an articulated position. A useful resource in this regard is the *Clinical Guidance for the Assessment and Implementation of Bed Rails In Hospitals, Long Term Care Facilities, and Home Care Settings* available as a link from the U.S. FDA website.

### **2.2.2 Legacy Beds**

The issue of patient entrapment in hospital beds is complex and affects manufacturers, healthcare practitioners and facilities, medical equipment suppliers, home health agencies, patients, and caregivers. Many beds currently in use may no longer have the original mattress or bed rails, and may present an entrapment hazard by increasing or creating gaps or spaces between various components of the bed system. The recommendations in this guidance therefore apply to most hospital beds, including legacy beds in various settings where health care is provided. As described above, a new hospital bed becomes a "legacy bed" as soon as it is placed into use.

Reducing the risk of entrapment involves a multi-faceted approach that includes bed design, clinical assessment and monitoring, as well as meeting patient, resident, and family needs for vulnerable patients in most health care settings - hospitals, long term care facilities, and at home. Therefore, comprehensive bed safety programs in these settings will likely involve input from manufacturers as well as facility staff. Recognizing that not all hospital beds present a risk of entrapment, and that this risk may vary depending on the patient, Health Canada encourages manufacturers and facilities to work together to develop bed safety programs to evaluate and, if needed, mitigate entrapment risk. A useful document for mitigation of these risks is a “*Guide for Modifying Bed Systems and Using Accessories to Reduce the Risk of Entrapment*” available as a link from the U.S. FDA website.

When evaluating the safe use of a hospital bed, component or accessory, caregivers should recognize that the risk for entrapment may increase if a hospital bed system is used for purposes, or used in a care setting, not intended by the manufacturer. Evaluating the dimensional limits of gaps in hospital beds may be one component of a bed safety program which includes a comprehensive plan for patient and bed assessment. Bed safety programs may also include plans for the reassessment of hospital bed systems. Reassessment may be appropriate when (1) there is reason to believe that some components are worn (e.g., rails wobble, rails have been damaged, mattresses are softer) and could cause increased spaces within the bed system, (2) when accessories such as mattress overlays or positioning poles are added or removed, or (3) when components of the bed system are changed or replaced (e.g., new bed rails or mattresses).

Health Canada recommends that healthcare facilities conducting a risk-benefit analysis to ensure that steps taken to mitigate the risk of entrapment do not create different, unintended risks or reduce clinical benefits available to patients using legacy beds. Such steps may include checking with manufacturers to identify compatible mattresses, rails, and accessories. Likewise, healthcare facilities may contact manufacturers or their suppliers for entrapment mitigating solutions that may already be available. Should a supplier put together and provide to healthcare facilities a bed system composed of components and accessories made by various manufacturers, it is the responsibility of the supplier to verify the complete bed system meets this guidance’s recommendations. Manufacturers should follow the appropriate Health Canada regulations when developing mitigation components, attachments and other accessories to address entrapment risks in legacy hospital beds.

Additional resources are available to help caregivers and health care providers assess the individual patient’s needs, consider and address entrapment risks, and recommend mitigation strategies. As well, Health Canada recommends that patients be re-assessed for risk of entrapment whenever there is a change in the patient’s medication or physical condition. A useful resource in this regard is the *Clinical Guidance for the Assessment*



*and Implementation of Bed Rails in Hospitals, Long Term Care Facilities, and Home Care Settings* available as a link from the U.S. FDA website. Appendix B provides examples of additional resources.

Healthcare facilities assessing beds currently in use need not measure beds in a facility all at once, all at one time, or only once. Evaluating the dimensional limits of the gaps in hospital beds is one component of an overall and ongoing assessment and mitigation strategy to reduce entrapment. Not all patients are at risk for an entrapment, and not all hospital beds pose a risk of entrapment. The manufacturer can help the healthcare facilities determine the level of risk for entrapment and take steps to mitigate the risk through a bed safety program. Reassessment may be appropriate when (1) there is reason to believe that some components are worn (e.g., rails wobble, rails have been damaged, mattresses are softer) and could cause increased spaces within the bed system, (2) when accessories such as mattress overlays or positioning poles are added or removed, or (3) when components of the bed system (e.g., new bed rails or mattresses) are changed or replaced.

### **2.2.3 Exclusions**

The dimensional criteria described in section 2.7 are recommended for a number of products, but not for all types of hospital beds. Below are those products for which some, or all, of the dimensional criteria are not recommended. Please note that the products listed below are not free from risk of entrapment. Users should regularly and consistently identify and address areas of potential entrapment for each patient or resident through a comprehensive bed safety program.

Total exclusion from the scope of this guidance:

- Air fluidized therapy beds are excluded because the nature of the therapy does not allow the patient to exit the bed easily. When these products are used, Health Canada recommends that steps be taken to ensure that the therapeutic benefit outweighs the risk of entrapment.
- Bariatric (obesity) beds, pediatric beds and infant cribs are excluded because Health Canada did not use anthropometric data for these groups in determining the recommended dimensional limits of the entrapment zones in this guidance.
- Stretchers not used for extended-stay, examination tables, operating room tables, radiology tables, proning tables, exercise and range of motion tables, bathing units, and mechanical lifting devices are excluded from the scope of this guidance because they are not ordinarily used as hospital beds.

Partial Exclusion from the scope of this guidance:

- Kinetic treatment tables and rotation beds are excluded from the dimensional limits except for those spaces within the perimeter of the rail due to the special design requirements of these beds (see Zone 1 description in section 2.7.1). When these products are used, Health Canada recommends that steps be taken to ensure that the therapeutic benefit outweighs the risk of entrapment.
- Labor, delivery, recovery, and postpartum (LDRP) specialty beds are excluded from the dimensional limits for the area under the rail at the end of the rail due to the special design requirements for obstetric care (see Zone 4 description in section 2.7.4).
- Pressure Reduction Therapeutic Products Framed flotation therapy beds (specialty air beds built into a hospital bed frame), powered air mattress replacements, and similar pressure reduction products that have therapeutic benefits such as reducing pressure on skin are easily compressed by the weight of a patient and may pose an additional risk of entrapment when used with conventional hospital bed systems. When these types of mattresses compress, the space between the mattress and the bed rail may increase and pose an additional risk of entrapment. While entrapments have occurred with the use of framed flotation therapy beds and air mattress replacements,<sup>12, 13</sup> these products are excluded from the dimensional limit recommendations, except for those spaces within the perimeter of the rail (see Zone 1 description in section 2.7.1). This partial exemption is due to the highly compressible nature of these mattresses, which poses technical difficulties with measuring certain dimensional gaps in these types of products. Future revisions of the IEC bed standard may address the risk of entrapment in bed systems using these products.

Additional caution should be taken when using these products to ensure a tight fit of the mattress to the bed system. If a powered air mattress is replacing a mattress on a bed system that meets the recommendations in the guidance with the original mattress, the resulting bed system with the new air mattress may now pose a risk of entrapment. When these products are used, Health Canada recommends that steps be taken to ensure that the therapeutic benefit outweighs the risk of entrapment.

---

12 Miles SH. Deaths between Bedrails and Air Pressure Mattresses, *Journal of the American Geriatrics Society* 2002; 50:1124-5.

13 Joint Commission on Accreditation of Healthcare Organizations, Issue 17 Sentinel Event Alert: *Bed Rail-Related Entrapment Deaths* (Sept. 6, 2002).

The substitution of the original mattress for a surface such as a powered air mattress, or the addition to the existing mattress of, for example, a mattress overlay, may have an effect on the height of the top of the side rail above the surface the patient lies on. This may have an impact on the potential for patient falls, and the user should be aware of this and perform a proper risk assessment. Likewise, suppliers of such mattress products should both warn and help facilities assess the potential impact these products may have on patient entrapment risks or patient falls. Also see section 2.8 for more information relating to side rail height.

Health Canada recommends the dimensional limits in this guidance for bed systems using mattress overlays. It is recommended that steps be taken to assess the therapeutic benefit to the patient when applying a mattress overlay to a bed system that does not meet the recommended dimensional limits. The clinical benefit should outweigh the risk of entrapment presented by the use of such a system. Also, for bed systems that do not meet the recommendations, some facilities may choose to add a mattress overlay to allow the bed system to meet the recommendations, however steps should be taken to ensure that the overlay is never accidentally removed as its absence could then present an entrapment risk.

## **2.3 Reporting Incidents**

### ***2.3.1 Reporting an Entrapment Adverse Event***

Health Canada will continue to monitor adverse event data on entrapments in hospital beds. Complete and descriptive reports of each entrapment or near-entrapment adverse event will help Health Canada monitor the safety of hospital beds and assess the effectiveness of this guidance. When reporting an entrapment event, manufacturers and users often leave out details of the entrapment event that can be useful in identifying the factors or conditions that led to the event. Consequently, these reports only tell Health Canada that an adverse event took place. To improve the quality of entrapment adverse event reports, the following information is important and helpful to include:

- the exact location or zone of entrapment (the zones described in this document and Appendix E can be used to help describe entrapment events);
- the body part that was entrapped, and, if possible, the size of the entrapped body part (i.e., head breadth, neck diameter, chest depth);
- the position of the rails (fully raised, intermediate, or lowered);
- type of rails in use (full length,  $\frac{3}{4}$  length,  $\frac{1}{2}$  length, split rails or  $\frac{1}{4}$  length), and the number of side rails raised at the time of the event;

- the articulation of the bed deck (which sections of the deck were raised, and the approximate degree of elevation for each deck section);
- mattress type, mattress height, length and width, and the height of the rail from the top of the mattress; and
- information on the size of the gap that contributed to the entrapment.

A detailed entrapment reporting form allowing the recording of this important information is available. It is strongly encouraged that both manufacturers and facilities that become aware of entrapment incidents use this form to report them to Health Canada. The *Bed-related Entrapment and Fall Report Form* can be found on the Health Canada website.

More information on reporting adverse events to Health Canada can be found in the document: *Mandatory and Voluntary Problem Reporting for Medical Devices*.

### **2.3.2 Reporting a Side Rail Latch Failure**

To report side rail latch failures or other problems with hospital beds, please consult the following Health Canada web page: *Mandatory and Voluntary Problem Reporting for Medical Devices*

As well, the entrapment reporting form would be helpful to describe the circumstances and bed used at the time of the latch failure.

## **2.4 Key Body Parts at Risk**

Three key body parts at risk for life-threatening entrapment in the seven zones of a hospital bed system discussed in this guidance are the head, neck, and chest. International anthropometric data references have been used to determine the relative sizes of these body parts for the population at greatest risk for entrapment and to provide a guide for the dimensional limits that would reduce their risk of entrapment. See Appendix D.

### **2.4.1 Head**

To reduce the risk of head entrapment, openings in the bed system should not allow the widest part of a small head (head breadth measured across the face from ear to ear) to be trapped. Country-specific anthropometric data show that a 1st percentile female head breadth may be as small as 95 mm (3 ¾ inches). A dimension of 120 mm (4 ¾ inches) encompasses the 5th percentile female head breadth in all data sources used to develop these recommendations, and includes 1st percentile female head breadth as reported in some data sources.

Health Canada is therefore using a head breadth dimension of 120 mm (4 ¾ inches) as the basis for its dimensional limit recommendations. This dimension is consistent with the dimensions recommended by the HBSW and the IEC.

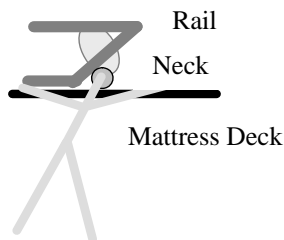

### Wedging of the Neck

#### 2.4.2 Neck

To reduce the risk of neck entrapment, openings in the bed system should not allow a small neck to become trapped.

Data shows a 1st percentile female neck diameter of 79 mm (3 1/8 inches) [5th percentile = 83 mm (3 1/4 inches)]. Several factors, such as neck compressibility, loss of muscle mass in the neck when people age, and the asymmetrical shape of the neck, support the use of a reduced measurement. For example, one published estimate for compressibility of neck tissue is 25% of the uncompressed measure.<sup>14</sup> Reducing the 79 mm measure by approximately 25% to account for tissue compression gives a measure of 60 mm (2 3/8 inches). Both the IEC and the HBSW recommend a dimensional limit of 60 mm (2 3/8 inches) to prevent neck entrapment. Consistent with these recommendations, Health Canada is recommending 60 mm (2 3/8 inches) as an appropriate dimension for neck diameter.

The concept of a wedging effect, which occurs when the neck is trapped in a V-shaped opening, recurs throughout many national and international entrapment-prevention standards (see Appendix C); however, the standards differ with respect to what is considered to be the critical angle for wedging. Some standards specify minimum angles to prevent neck entrapment based on a theoretical analysis of the forces on a cylindrical object (representing the cross-section of a neck) in an angled space. Depending on whether the wedging is considered to be caused by the total resultant forces on the neck or the horizontal components of the forces, the critical angles are identified as either 60 (see Appendix C, References 5 and 6) or 53 degrees (rounded up to 55) (see Appendix C, References 1,4 and 9), respectively.

---

14 ASTM International. "Standard Consumer Safety Specification for Expansion Gates and Expandable Enclosures." **Annual Book of ASTM Standards**, Vol. 15.07, Appendix X2, Designation F 1004.

When developing its recommendations for preventing neck entrapment, HBSW consulted a published international standard for swimming pool equipment [EN 13451], which includes dimensional limits to prevent entrapment of various body parts of adults and children. This standard specifies that V-shaped openings should be of angles greater than 60 degrees. HBSW members performed analyses that support this limit, and the HBSW has recommended that V-shaped openings be greater than 60 degrees to avoid neck entrapment.

Given the adult population at risk for wedging entrapments in hospital beds, Health Canada is recommending a dimension of 60 mm (2 3/8 inches) to represent neck diameter.

Additionally, to prevent wedging, a limit of greater than 60 degrees is recommended for V-shaped openings greater than 60 degrees through which a neck could enter. These dimensions are consistent with the dimensions recommended by the HBSW and the IEC (see IEC 60601-2-38-1).

### **2.4.3 Chest**

The openings in a bed system should be wide enough not to trap a large chest through the opening between split rails. For purposes of the recommendations in this guidance, a 95<sup>th</sup> percentile male chest depth is used to represent the largest chest measure. Although one would assume that the largest chest size belongs to women, breast tissue is compressible and diminishes in size as aging occurs. Male chests, however, have less compressible tissue and do not diminish as significantly in size with aging. A 95<sup>th</sup> percentile male chest depth of 318 mm (12 ½ inches), measured from the nipple through to the back, including the pectoral muscles, is used to represent the largest chest measure.

The IEC is proposing to adopt a dimension to reduce chest entrapment of greater than 318 mm (12 ½ inches). Health Canada concurs with the dimension of 318 mm (12 ½ inches) to represent chest depth for the population vulnerable to entrapment, and has used this dimension as the basis for its recommended dimensional limits.

The body part dimensions used to develop Health Canada's dimensional limit recommendations are summarized in Table 2 below.

<b>Key Body Part</b>	<b>Dimension</b>
Head	120 mm (4 ¾ inches)
Neck	60 mm (2 3/8 inches) and an angle > 60 degree
Chest	318 mm (12 ½ inches)

## 2.5 Potential Zones of Entrapment

This guidance describes seven zones in the hospital bed system where there is a potential for patient entrapment. Entrapment may occur in flat or articulated bed positions, with the rails fully raised or in intermediate positions. Descriptions of the seven entrapment zones appear in section 2.7 in this guidance. Summary drawings of entrapment for all of the zones appear in Appendix E.

The seven areas in the bed system where there is a potential for entrapment are identified in the drawing below.

- Zone 1:** Within the Rail
- Zone 2:** Under the Rail, Between the Rail Supports or Next to a Single Rail Support
- Zone 3:** Between the Rail and the Mattress
- Zone 4:** Under the Rail, at the Ends of the Rail
- Zone 5:** Between Split Bed Rails
- Zone 6:** Between the End of the Rail and the Side Edge of the Head or Foot Board
- Zone 7:** Between the Head or Foot Board and the Mattress End

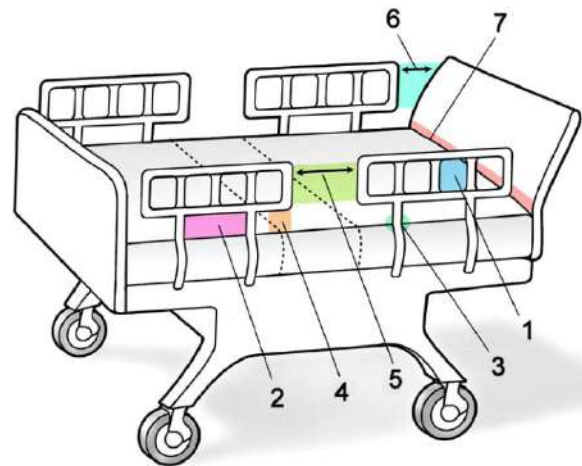

## **Entrapment at the Bed Deck or Frame:**

Many of the entrapment event reports FDA received involved entrapment between the rail and the bed's "frame." It is unclear from the event descriptions whether this refers to the mattress deck, the bed frame, or even the hardware attaching the bedrail to the bed system. While this guidance does not recommend dimensional limits on the space at the deck or frame locations, FDA and Health Canada believe that meeting the other recommended dimensional limits would reduce the possibility of entrapment at the deck or frame locations.

### **2.6 A Retrospective Study of Entrapment Reports to FDA**

FDA's adverse event reporting system helps promote product safety by collecting information on products that are currently on the market. FDA's reporting system collects reports of adverse events<sup>15</sup> that caused or may have caused a death, a serious injury, or a malfunction. While Health Canada has a similar reporting system, the number of incidents reported in the United States is much greater than in Canada for 2 reasons:

- 1) Health care facilities in the United States are required to report to FDA serious incidents; in Canada reporting by facilities is voluntary,
- 2) The United States' population is roughly 10 times that of Canada's. As a member of the HBSW, Health Canada chose to participate in the analysis of the adverse events reported to FDA, which could have occurred here in Canada as well.

From January 1985 to March 2000, FDA received 390 entrapment event reports to its adverse events database from manufacturers, hospitals, nursing homes, and consumers. In 2000, HBSW reviewed these adverse event reports and identified entrapment areas or zones in the bed system and the body parts at risk. Based on its analysis of the reported adverse events, HBSW made recommendations for dimensional limits.

A retrospective study conducted by members of HBSW compared the HBSW recommended dimensions with dimensions of the bed models identified in the adverse events reports. For each of the entrapment adverse events in the study where the model number of the bed was reported, a

---

15 Note: Many reports lacked a complete and detailed description of the adverse event. The beds involved in these adverse events may not have had compatible mattresses or bed rails specifically designed for the particular bed model involved in the reported entrapments. Also, information was limited regarding the condition of the beds, bed rails, and mattress at the time of the entrapments. Specific details about the exact location of the entrapments within the beds were sometimes lacking. Despite these limitations, adverse event reports can suggest a profile of the areas or locations on a hospital bed where entrapment can occur, as well as the parts of the body at risk for entrapment.



participating bed manufacturer provided information on the dimensions of the identified area where an entrapment was believed to have occurred<sup>16</sup>. Four manufacturers provided this information. These data represented 215 (55%) of the 390 entrapment events. This information provided a reference range typical of hospital beds currently available for use in acute, long term care, and home settings. The retrospective study compared the manufacturer-supplied information, in the aggregate, to the dimensions recommended by the HBSW. If the size of the openings in the reported bed models did not meet the HBSW recommended limits, i.e., the openings in the reported beds were outside the limits of the recommended gap sizes, then the HBSW dimensional limits were considered to be an appropriate limit to reduce entrapments at that area. The information from this study was considered in developing the dimensional limit recommendations described in this guidance.

## **2.7 Dimensional Limits for Identified Entrapment Zones 1-4**

Health Canada is recommending dimensional limits for only zones 1 through 4 at this time because it is believed the majority of the entrapments reported to FDA and Health Canada have occurred in these zones. Health Canada based these recommended limits upon the body parts entrapped in these individual zones identified through adverse event reports and entrapment scenarios described in the reports. A summary table (Table 3) of the hospital bed dimensional limit recommendations appears in Section 2.7.9 at the end of this section.

The Hospital Bed Safety Workgroup developed and validated test methods to measure and assess gaps or openings in zones 1-4 of hospital bed systems; these are shown in Appendix F. As a member of the HBSW, Health Canada participated in the development and validation of these test methods. Health Canada recommends these test methods as an acceptable approach for assessing hospital bed gap sizes in accordance with the dimensional limitations described below. The tool used to conduct these tests is available through the supplier identified in Appendix B. If an alternate approach is used to assess gap sizes, Health Canada recommends that the dimensional limits and test methods used in any alternative approach be at least as stringent as the ones described below.

---

16 When manufacturers measured the gaps for the retrospective study, they used mattresses of the size, type and thickness typically recommended for use with their bed models. Mattresses involved in reporting entrapment events may have been different from the manufacturers' recommended mattresses, which means actual gap sizes in entrapments involving the mattresses may have been different from those identified by the manufacturers in the retrospective study. The manufacturers' measurements may have been representative of "best case measurements". Spaces in a hospital bed system may vary in size when the hospital bed system is articulated through the various ranges of motion. For the retrospective study, manufacturers measured gap sizes with the beds in the flat position. This means that if the bed was articulated in reported entrapments, the size of the gap may have been different from that provided by the manufacturers in the retrospective study.

It is important to note that the forthcoming revision to the IEC standard is expected to incorporate the same dimensions listed in Table 2 for the body parts that are at risk of entrapment. However, as noted earlier, the IEC standard does not include the mattress as part of its assessment procedure of the entrapment zones (except zone 3 which is defined as the space between the rail and mattress). Therefore, for some tests in the forthcoming revision to the IEC standard, the IEC standard may be more stringent than this guidance. Review of this guidance will likely occur after publication of the IEC standard's revision, and some changes may be made to the guidance to harmonize it with the international standard. Manufacturers are urged to ensure that their beds meet both this guidance and the published version of the IEC standard at all times.

### **2.7.1 Zone 1 – Within the Rail**

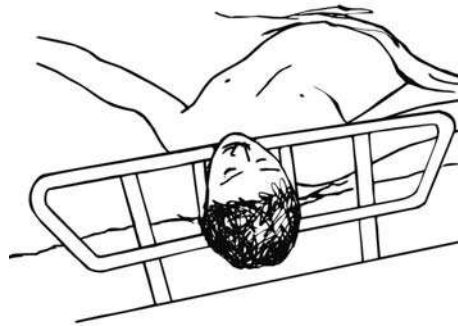

Zone 1 is any open space within the perimeter of the rail. Openings in the rail should be small enough to prevent the head from entering. A loosened bar or rail can change the size of the space. The HBSW and IEC recommend that the space be less than 120 mm (4  $\frac{3}{4}$  inches), representing head breadth.

#### **Data from the Retrospective Study**

Adverse events identified as occurring within the rail were reported in bed models where open spaces within the rail were greater than 120 mm (4  $\frac{3}{4}$  inches). Manufacturers' measurements of bed models representative of those identified in these incidents had spacing within the rail of between 177 mm (6.97 inches) and 190 mm (7.48 inches). The data suggest that nearly all of these entrapment events may have been prevented if the spaces within the rails had been less than 120 mm (4  $\frac{3}{4}$  inches), representing head breadth as described above. Consistent with HBSW's and the IEC's recommendations, Health Canada is recommending a measure of less than 120 mm (4  $\frac{3}{4}$  inches) as the dimensional limit for any open space within the perimeter of a rail. The space should not permit an object with a circular cross-section measuring less than 120 mm (4  $\frac{3}{4}$  inches) in diameter to enter or pass through.

### 2.7.2 Zone 2 - Under the Rail, Between the Rail Supports or Next to a Single Rail Support

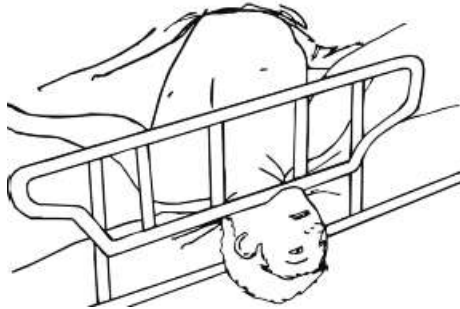

This space is the gap under the rail between a mattress compressed by the weight of a patient's head and the bottom edge of the rail at a location between the rail supports, or next to a single rail support. If there is a single rail support, entrapment in Zone 2 can occur anywhere along the bottom length of the rail beyond the support, up to the end of the rail (Entrapment at the end of the rail is explained in Zone 4). Factors to consider are the mattress compressibility<sup>17</sup> which may change over time due to wear, the lateral shift of the mattress or rail, and any degree of play from loosened rails or rail supports. A restless patient may enlarge the space by compressing the mattress beyond the specified dimensional limit. This space may also change with different rail height positions and as the head or foot section of the bed is raised and lowered. The space may increase, decrease, become less accessible, or disappear entirely. In some positions, the potential for entrapment in this zone may still exist when the deck is articulated.

Preventing the head from entering under the rail would most likely prevent neck entrapment in this space. Health Canada recommends that this space be small enough to prevent head entrapment, less than 120 mm (4 ¾ inches). IEC recommends the same dimensions but measures the space without the mattress in place.

#### Data from the Retrospective Study

In the study, the manufacturers were instructed to measure diagonally from the top edge of the compressed mattress to the lowest inside edge of the rail between the rail supports. This measurement ranged from between 76 mm (3 inches) and 191 mm (7.5 inches). If the reported entrapments occurred at Zone 2, the data suggest that the HBSW recommended dimensional limit of less than 120 mm (4 ¾ inches) would have prevented only about half of the reported events at this zone. At times, the adverse event report

---

17 “Mattress compressibility” refers to the extent to which a mattress changes in dimension as a result of the weight of a patient's body or body part moving on, across, or off of the mattress surface. The mattress dimension may also change as a result of articulation of the deck.

information was not clear, and it was difficult to determine the precise location of the entrapment and to determine whether it occurred in Zone 2, 3, or 4. Most reports only stated that an entrapment occurred “between the rail and the mattress.” However, given the scenarios in the reports, some of these events may have occurred at the rail end, beyond the support (Zone 4) as neck entrapments when the head entered under the rail first.

Because the data for reported entrapments at Zone 2 are not definitive and the most likely scenario for entrapment in this space would include a head-first entry, the dimensional limit of 120 mm (4 ¾ inches) is being recommended.

### **2.7.3 Zone 3 - Between the Rail and the Mattress**



This area is the space between the inside surface of the rail and the mattress compressed by the weight of a patient’s head. The space should be small enough to prevent head entrapment when taking into account the mattress compressibility, any lateral shift of the mattress or rail, and degree of play from loosened rails. HBSW and IEC recommend a dimension of less than 120 mm (4 ¾ inches) since this dimension represents head breadth, the narrowest part of the head. Health Canada is recommending a dimensional limit of less than 120 mm (4 ¾ inches) for the area between the inside surface of the rail and the compressed mattress.

### **Data from the Retrospective study**

A review of the manufacturers’ supplied measurements indicates that the horizontal gap between the rail and the uncompressed mattress for bed models involved in entrapments believed to have occurred at Zone 3 was between 38 mm (1 ½ inches) and 127 mm (5 inches). Theoretically, entrapment would involve compression of the mattress which would have resulted in a larger gap than the manufacturer measurements without patients present and, subsequently, a larger range of measures. Further, it could not be determined from the description of entrapment events whether entrapments occurred at Zones 2, 3 or 4.

Health Canada recommends a 120 mm (4 ¾ inches) dimensional limit for this zone based on the head breadth dimension described above.

#### **2.7.4 Zone 4 - Under the Rail at the Ends of the Rail**



This space is the gap that forms between the mattress compressed by the patient, and the lowermost portion of the rail, at the end of the rail. Factors that may increase the gap size are: mattress compressibility, lateral shift of the mattress or rail, and degree of play from loosened rails. The space poses a risk for entrapment of a patient's neck. It may change with different rail height positions and as the head or foot section of the bed is raised and lowered. The space may increase, decrease, become less accessible, or disappear entirely. Thus, in some positions, the potential for entrapment in this zone may still exist when the deck is articulated.

At the time of this publication, the IEC international standard recommends a dimensional limit of less than 60 mm (2 3/8 inches) measured between the mattress support platform and the lowest portion of the rail at the rail end to prevent neck entrapment. Based on the neck diameter dimension described above, Health Canada recommends that the dimensional limit for this space also be less than 60 mm (2 3/8 inches), however, based on the work done at HBSW, this measurement is made between the rail and the mattress, with a test tool compressing the mattress (IEC measures from the mattress support platform, without the mattress in place). To reduce the risk of neck entrapment at Zone 4, Health Canada recommends consideration of the combination of the gap size and the angle size (created between the mattress and the rail). Thus, Health Canada recommends that the V-shaped opening under the rail at its end be of an angle wide enough, i.e. greater than 60 degrees, to prevent wedging entrapment (see Neck Section for a description (section 2.4.2) and diagram (section 2.4.1) of wedging entrapments).

#### **Data from the Retrospective Study**

The retrospective study measures for Zone 4 ranged between 102 mm (4 inches) and 152 mm (6 inches) for the diagonal measure between the inside bottom edge of the rail at the end of the rail and the top of the compressed mattress. It could not be determined from

the entrapment event reports whether the entrapments occurred in Zone 4, or whether events reported as neck entrapment occurred as a result of head-first entry. The HBSW recommended that a 60 mm dimension be used to represent neck diameter. Later the HBSW identified the importance of avoiding wedging of the neck at the end of the rail, and concluded that a linear measure for the Zone 4 space would not adequately address mattress compressibility and wedging forces in Zone 4. HBSW recommended that openings in Zone 4 measure both less than 60 mm in size and greater than 60 degrees in angle. Health Canada agrees with this recommendation.

### **Zones 5, 6 and 7**

Although seven potential zones of entrapment have been identified by HBSW, Health Canada is recommending dimensional limits for zones 1-4 because these zones were most frequently reported as having entrapments. Between 1980 and April 2006, Zone 1 to 4 incidents of entrapment accounted for 72.5% of all entrapment incidents reported to Health Canada, and 73% of all entrapment deaths. The current international standard (IEC 60601-2-38) addresses limits for zones 1, 2, 4, 5 and 6. In addition, IEC intends to set or revise dimensional limits, for areas comparable to HBSW's zones 1-6 in their upcoming revision of the international standard for hospital beds. Health Canada and FDA continue to receive entrapment reports for Zones 5 and 6, and Zone 7 remains a potential for entrapment. Health Canada and FDA will monitor entrapments in these zones and consider harmonization with the revised IEC standard once it is available.

In the meantime, if these zones are of concern (e.g., for a particular patient, for a particular bed system), the published version of IEC 60601-2-38 should be consulted for new bed designs and mitigation strategies such as those described in *A Guide for Modifying Bed Systems and Using Accessories to Reduce the Risk of Entrapment* (available as a link from the U.S. FDA website) should be used for older, legacy beds.

#### **2.7.5 Zone 5 – Between Split Bed Rails**

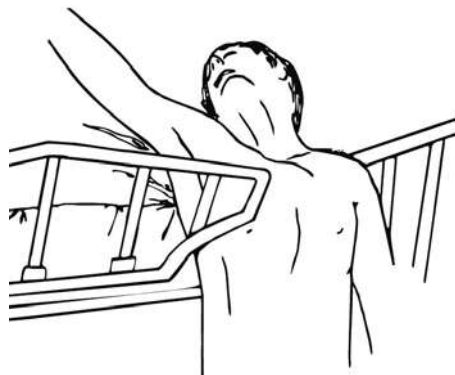

See the prelude (Zones 5, 6, and 7 above). This zone occurs when partial or split length head and foot side rails (split rails) are used on the same side of the bed. The space between the split rails may present a risk of either neck entrapment or chest entrapment between the rails if a patient attempts to, or accidentally, exits the bed at this location. In addition, any V-shaped opening between the rails may present a risk of entrapment due to wedging. Health Canada recognizes this area as a potential for entrapment and encourages manufacturers and facilities to report entrapment events at this zone.

**2.7.6 Zone 6 - Between the End of the Rail and the Side Edge of the Headboard or Footboard**

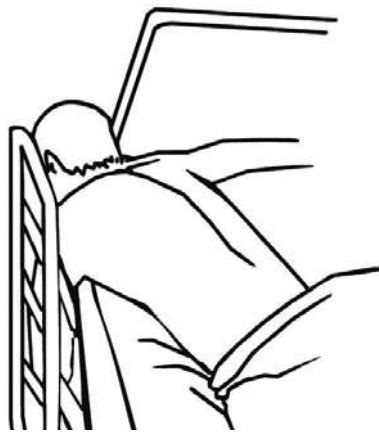

See the prelude (Zones 5, 6, and 7 above). Zone 6 is the space between the end of the rail and the side edge of the headboard or footboard. This space may present a risk of either neck entrapment or chest entrapment. In addition, any V-shaped opening between the end of the rail and the headboard or footboard may present a risk of entrapment due to wedging. This space may change when raising or lowering the head or foot section of the bed. This space may increase, decrease, become less accessible, or disappear entirely. Thus, in some positions, the potential for entrapment may exist when the deck is articulated. Health Canada recognizes this area as a potential for entrapment and encourages manufacturers and facilities to report entrapment events at this zone.

### **2.7.7 Zone 7 - Between the Headboard or Footboard and the End of the Mattress**

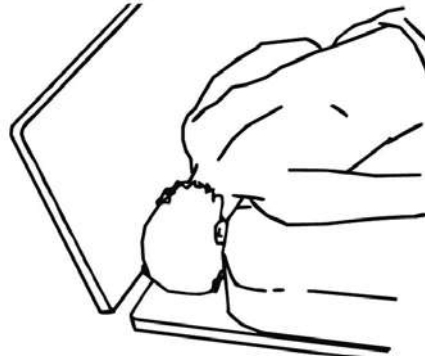

See the prelude (Zones 5, 6, and 7 above). Zone 7 is the space between the inside surface of the headboard or footboard and the end of the mattress. This space may present a risk of head entrapment when taking into account the mattress compressibility, any shift of the mattress, and degree of play from loosened headboard or footboard. Health Canada recognizes this area as a potential for entrapment and encourages manufacturers and facilities to report entrapment events at this zone.

### **2.7.8 Comparison of IEC Bed Standard and Health Canada Guidance**

It is important to note that for Zones 2 and 4, both IEC and the Health Canada guidance have the same dimensional requirements, i.e., 120 mm and 60 mm respectively. However, in the case of IEC, the measurements are taken from the mattress support platform, while the Health Canada guidance takes the measurements from the compressed mattress surface.

The Health Canada guidance tests are more realistic, as the bed is never used without a mattress. However, the mattress itself does introduce a variable as the manufacturer may recommend various size or types (compressibility) of mattresses for any one bed, and the user facility may replace mattresses during the life of the bed with some that do not meet the original bed manufacturer's recommended mattress specifications. Deviation from these specifications could result in larger gaps that are potentially hazardous.

To eliminate this risk, IEC chose to test without a mattress. This ensures greater repeatability of testing and ensures that regardless of the mattress used with the bed, the bed will always pass the recommended dimensional limits. However, this approach results in far more stringent requirements as the mattress can no longer be used to reduce any gaps between the mattress support platform and the rail. In some countries such as Canada, the regulatory authorities require that electrically-operated medical devices meet



the Canadian electrical code. This code requires that hospital beds meet the published version of the IEC 60601-2-38 standard.

Therefore, manufacturers will need to consider both published IEC requirements as well as the recommendations in this guidance and ensure their beds meet both.

Zone 3 uses the same dimensional limits for both IEC and the Health Canada guidance, and the test methods is the same for both i.e. the mattress is used in the test procedure.

### ***2.7.9 Entrapment Between Components of Bed System and Accessories***

While the discussion above and the test methods below in Appendix F focus on entrapment between various parts of the bed that are essential components of the bed system (i.e. mattress, rails, boards), they do not address potential entrapment at locations where accessories may be placed, such as IV poles. For example, in Zone 6 which is not addressed by the Health Canada guidance but is covered in the IEC standard, the introduction of an IV pole in or near some of these zones can cause a potential entrapment hazard where none existed before because the space between the accessory and the bed component can be small enough or at an angle that will be conducive to entrapment.

Therefore, manufacturers are urged to consider the effect such accessories may have on their beds and to take appropriate precautions by designing the bed and the accessories or the location of these accessories to mitigate these risks. Methods used to assess these risks of entrapment can be based on those used in Appendix F. Where redesigning of the bed (or accessory) is not possible or cannot address the risk, appropriate user warnings and labeling must be considered.

**Table 3 Summary of Health Canada's Hospital Bed Dimensional Limit Recommendations**

Zone	Dimensional Limit Recommendations
1 Within the rail	< 120 mm (< 4 3/4 inches)
2 Under the rail, between rail supports or next to a single rail support	< 120 mm (< 4 3/4 inches)
3 Between rail and mattress	< 120 mm (< 4 3/4 inches)
4 Under the rail, at the ends of the rail	< 60 mm (< 2 3/8 inches) AND > 60° angle

**NOTE:** the above dimensions should be assessed only when the test methods described in Appendix F are used.

## 2.8 Side Rail Height

Since the height of the rail above the mattress is not related to entrapment, this Health Canada guidance does not specify a minimum side rail height above the top of the mattress when the rails are in the “up” position.

As a point of information, recommendations vary among standards writing organizations regarding the minimum height of the top of the rail above the mattress. For hospital beds specifically, the international hospital bed standard, IEC 60601-2-38, amended in 1999, recommends 220 mm. However, the U.S. Consumer Products Safety Commission in 16 CFR Parts 1213 and 1513, *Consumer Product Safety Standard for Bunk Beds* recommends 5 inches (127 mm) as the minimum height, as does the American Society for Testing and Materials (ASTM) in ASTM F1427-06.

When designing the height of side rails, it is important for the manufacturer to consider the following:

- a) Is the side rail sufficiently high when raised that it will prevent the patient population that could be placed in it from accidentally falling out of bed, by rolling over the rail? Consideration must be given to the size of these patients and their mobility.
- b) Does the side rail, when lowered, provide sufficient clearance that it will not impact the care giver's feet?
- c) Is the top of the side rail, when lowered, sufficiently low that it will not press against the back of the patient's knees when the patient sits on the edge of the mattress and compresses the mattress by his or her weight?

## **2.9 Side Rail Latch Reliability - Requirements and Test Methods**

Side rail latches/locks should remain secure when subjected to the forces of normal use. Latches should be designed in such a way that they will provide a certain measure of reliability and protection from premature wear.

An appropriate test method to assess whether the rail's latch meets this recommendation is as follows. Forces are applied at the worst case accessible location.

Cycle the side rail mechanism (from the latched, upper position, to the unlatched, lowered position, and back to the latched, upper position) for 30,000 cycles. A force, as specified below, shall then be applied to the worst case accessible position for locking/latching of the side rail in the direction of unlatching/unlocking. The side rail shall not become unlatched/unlocked or create any other unacceptable risk.

Rail latches should be designed so that once raised, they cannot appear to have locked in place (rail does not drop) without the latch actually being securely engaged. Side rails should withstand the forces applied during reasonably foreseeable misuse over the product life cycle without creating an unacceptable risk.

The following test is to be used, after the 30,000 cycles of unlatching and latching:

- a) Lateral force cycling test. Exert a force of 100 N that is perpendicular to the side rail and applied at the worst case accessible location of the side rail in the direction indicated by E, or F in Figure 1 below. Reverse direction. Repeat for 3,000 cycles.

- b) Longitudinal force cycling test. Exert a force of 100 N on the side rail, applied at the worst case accessible location, in the lengthwise direction of the side rail as indicated by C, or D in Figure 1 below. Reverse direction. Repeat for 3,000 cycles.
- c) Vertical force cycling test. Exert a force of 100 N on the side rail, applied at the worst case accessible location, in the vertical direction of the side rail as indicated by B, or A in Figure 1 below. Repeat for 3,000 cycles.
- d) Upon completion of a), b) and c) above, apply a static load at the worst case accessible location, in the direction shown in Figure 1 below, and of the following magnitudes: A, C, D, E, F: 500 N, B: 750 N. The side rail should not become unlatched/unlocked or create any other unacceptable risk.

**NOTE:** The manufacturer shall take into account when these forces can be applied in the lowered position.

**NOTE:** The IEC working group developed the above test. However, this test procedure is still being worked on. Therefore, further modifications to this test may be forthcoming. The changes may include a low frequency and low force pulsating test for a), b) and c) that will simulate a patient who, perhaps as part of a nervous system disorder, repeatedly shakes the rail back and forth or side to side. Total cycles may be substantially increased from the current 3,000 cycles.

It is the healthcare facility staff's responsibility to confirm the side rail is properly latched before leaving the patient's bed. That being said, the manufacturer has a duty to ensure the latch's design is not subject to premature wear and that it is reliable, i.e. not subject to premature wear and must not allow the side rail to appear latched in the raised position when it is not fully locked in place.

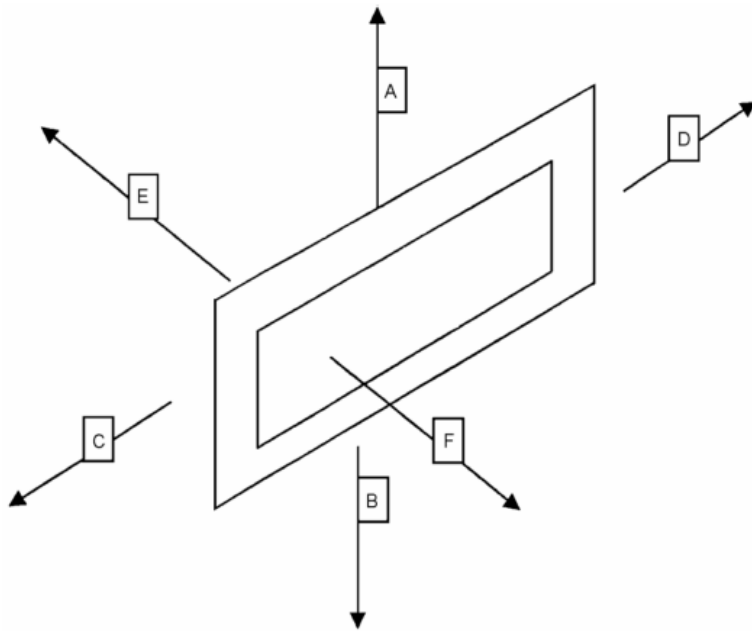

Figure 1: Application of forces for test of side rail latch

## 2.10 Mattress Compatibility Information

The bed should be marked with mattress compatibility information to ensure that in the event that the user manual is misplaced and that the manufacturer cannot be contacted to obtain this information, users know what mattress specifications they need to supply to their mattress supplier when the mattress needs replacing.

A mattress of the improper type, size, or thickness can lead to enlarged gaps at several zones of entrapment, thus creating potential entrapment hazards. The manufacturer should therefore provide the following mattress specifications at a location where this information will be clearly and permanently visible on the bed, for example on the mattress support platform. Health Canada recommends providing this information on the top surface of the mattress support platform. The information to provide is as follows:

- Mattress width,
- Mattress length,
- Mattress thickness and density
- Any other information which will help the facility obtain the best mattress for the bed system to meet the guidance's recommendations.

The end user should test any mattress for compatibility with the bed prior to use, to ensure the bed and mattress combination meets the recommendations of this guidance.

In addition, materials used in the construction of the mattress, as well as any mattress cover should be fire-resistant. Although, as an accessory to a bed (medical device) a mattress is by definition a medical device as well, it is recommended that hospital bed mattresses meet the minimum flammability requirements set out in the *Hazardous Products Mattresses Regulations*. (See Health Canada or Justice Canada website). Additional information is available by searching the Health Canada website for “Mattresses, Futons and Bedding. Facilities may choose to follow more stringent flammability requirement for any of their mattresses, such as in California technical bulletins TB 121 or TB 129; for more information, search the web for the California Bureau of Home Furnishings and Thermal Insulation and look at “flammability requirements of CAN/ULC-S137-07, *Standard Method of Test for Fire Growth of Mattresses (Open Flame Test)*, recently published in July 2007. Note that the standard does not apply to mattress toppers less than 25 mm thick, liquid and gas filled tickings (e.g. water beds and air mattresses with no upholstery material between the ticking and the core), and certain other specified products.

As indicated in 2.2, Detailed Scope, the specifications in this Guidance and the tools and methods used to measure gaps were produced considering an adult population's size and for use with beds designed for care of the adult patient. The dimensions specified to limit gaps are not appropriate to children. Healthcare facilities should not, without proper assessment, use adult hospital beds for all children who no longer sleep in a crib. Adult beds are an entrapment risk to young children and to older children with physical and developmental disabilities. Manufacturers should therefore indicate, both in the bed's instruction manual and somewhere visible on the bed itself wording such as "This bed is for use with adult patients; use of the bed may present a life-threatening entrapment hazard to young children and to older children with physical and developmental disabilities.

## **2.11 Other Hazards**

The purpose of this guidance is to focus attention primarily on the issue of entrapment and side rail latch reliability. However, manufacturers (and users) should be aware that there are other types of bed-related failures that are reported to Health Canada. Knowledge of these failures and their frequency could help manufacturers pay particular attention to these areas in the design of their beds to help limit the number of incidents. Please see the chart below for a listing of the incidence of bed problems.

FDA has reported a number of fires with electrically-operated hospital beds. A document entitled “*FDA Public Health Notification: Safety Tips for Preventing Hospital Bed Fires*” is available from the U.S. FDA website.

## Incidence of bed problems Reported to Health Canada 1980 to April 2006

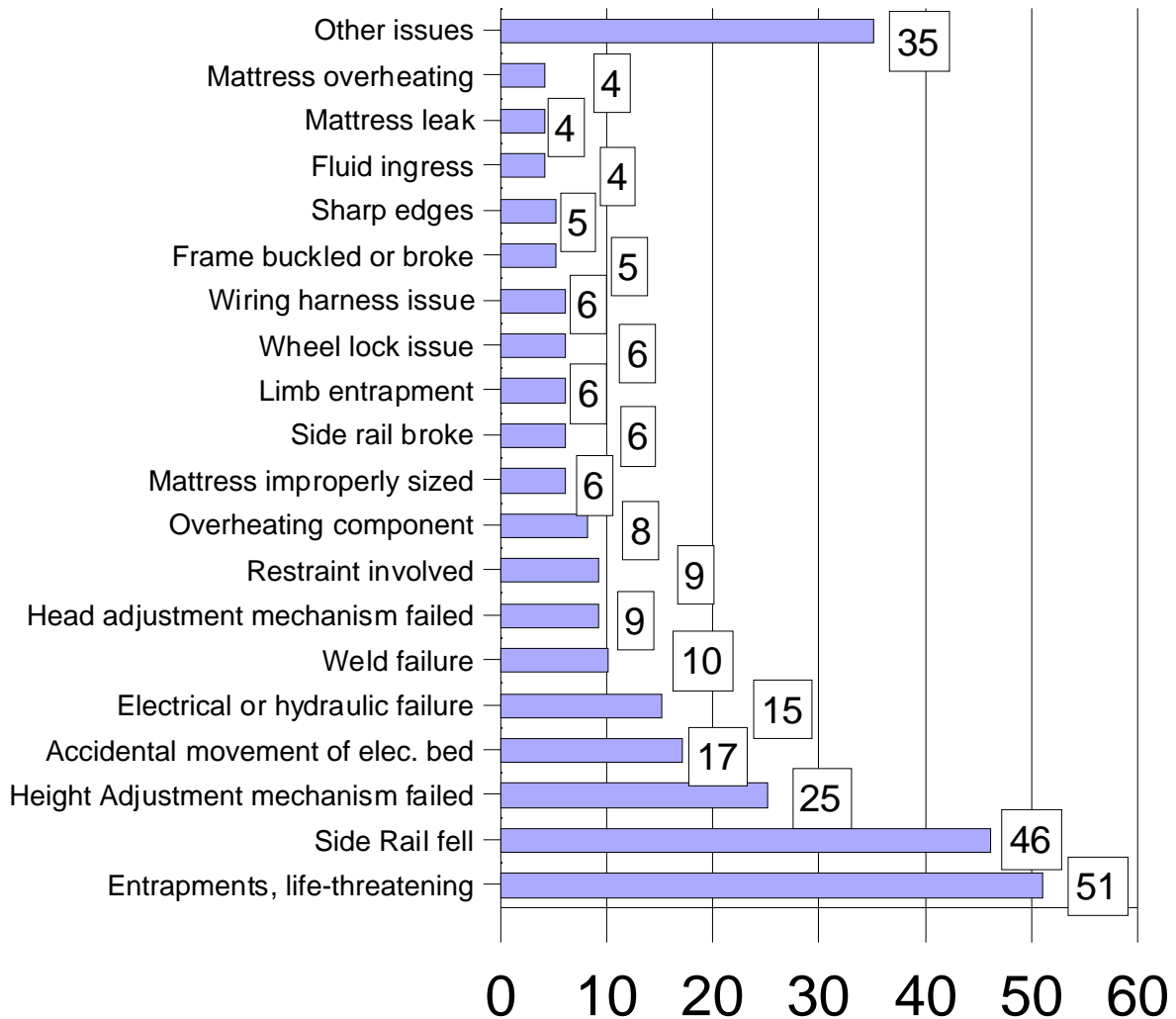

**NOTE:** "Other Issues" include the following types of incidents:

Headboard or footboard falling:	2
Mattress sliding:	3
Mattress fires:	1
Wheelbolt failing:	1
Scale failure:	1

## **APPENDIX A List of Hospital Bed Safety Workgroup (HBSW) Participating Organizations**

- AARP
- American Association of Homes and Services for the Aging (now Leading Age)
- American Health Care Association
- American Medical Directors Association
- American Nurses Association
- American Society for Healthcare Risk Management/American Hospital Association
- Basic American Metal Products
- Beverly Enterprises, Inc.
- Care Providers of Minnesota
- Carroll Healthcare, Inc.
- ECRI
- ElderTech Solutions, LLC
- Exceptional Parent Foundation For Education
- Evangelical Lutheran Good Samaritan Society
- Hard Manufacturing Co., Inc.
- HealthSafe Inc.
- Hill Rom, Inc.
- Huntleigh Healthcare
- Iona Senior Services
- Kinetic Concepts, Inc.
- Law Offices of Julie A. Braun
- Lockwood Consulting, LLC
- Medical Devices Bureau, Health Canada
- M.C. Healthcare Products
- National Association for Home Care
- National Citizens Coalition for Nursing Home Reform
- National Patient Safety Foundation/American Medical Association
- Posey Company
- RN+ Systems / Tactilitics, Inc.
- Span-America Medical Systems, Inc.
- Stryker Medical
- Sunrise Medical, Inc.
- The ROHO Group, Inc.
- Untie the Elderly, The Kendal Corporation
- U.S. Department of Veterans Affairs
- U.S. Food and Drug Administration
- Vail Products Inc.



Consulting Organizations to the Hospital Bed Safety Workgroup

- Joint Commission on Accreditation of Healthcare Organizations
- U.S. Centers for Medicare & Medicaid Services
- U.S. Consumer Product Safety Commission

## **APPENDIX B Additional Information and Kit Information**

### Websites:

Food and Drug Administration:

<http://www.fda.gov/cdrh/beds>

Bureau of Medical Devices, Health Canada:

[http://www.hc-sc.gc.ca/dhp-mps/md-im/index\\_e.html](http://www.hc-sc.gc.ca/dhp-mps/md-im/index_e.html)

ECRI:

[https://www.ecri.org/Documents/Patient\\_Safety\\_Center/BedSafetyClinicalGuidance.pdf](https://www.ecri.org/Documents/Patient_Safety_Center/BedSafetyClinicalGuidance.pdf)

SafeHealth, Inc.:

<http://www.safehealth.org/>

Untie the Elderly, Kendal Corporation:

<http://www.ute.kendal.org>

American Association of Homes and Services for the Aging (now Leading Age):

<http://www.leadingage.org/>

American Health Care Association:

<http://www.ahca.org>

### Kit Information:

The HBSW Bed Safety Entrapment Kit is available through National Safety Technologies at <http://www.nst-usa.com>. The kit includes:

### Documents

- *A Guide to Bed Safety* (a brochure) from the Hospital Bed Safety Workgroup
- *Clinical Guidance and Decision Tree for the Assessment and Implementation of Bed Rails in Hospitals, Long Term Care Facilities and Home Care Settings* from the Hospital Bed Safety Workgroup
- *Dimensional Test Methods for Bed Systems* from the Hospital Bed Safety Workgroup
- *Instructional Video/DVD for bed measurement*
- *A Guide for Modifying Bed Systems and the Use of Accessories to Reduce the Risk of Entrapment* from the Hospital Bed Safety Workgroup

### Test tool

Educational videotapes:

- An educational videotape, *Do No Harm – Hospital Bed Safety*, explaining hospital bed and bed rail safety issues is produced by AARP.

The AARP video is available through The Kendal Corporation. Ordering information can be obtained from <http://www.ute.kendal.org/>

## **APPENDIX C References for National and International Entrapment Standards**

1. ASTM International. “Standard Consumer Safety Performance Specification for Playground Equipment for Public Use.” Annual Book of ASTM Standards, Vol. 15.07, Designation F 1487.
2. ASTM International. “Standard Consumer Safety Specification for Expansion Gates and Expandable Enclosures.” Annual Book of ASTM Standards, Vol. 15.07, Designation F 1004.
3. ASTM International. “Standard Consumer Safety Specification for Bunk Beds.” Annual Book of ASTM Standards, Vol. 15.07, Designation F1427-06.
4. U.S. Department of the Army. “Child Development Center Play Area Inspection and Maintenance Program.” Publication No. TM 5-663.  
Public domain document available at [www.army.mil](http://www.army.mil)
5. European Committee for Standardization. “Playground Equipment – Part 1: General Safety Requirements and Test Methods.” Ref. No. EN 1176-1.  
Adopted and published under various national designations by 28 member countries of CEN, including France, Great Britain, Germany, and Sweden.
6. European Committee for Standardization. “Swimming Pool Equipment – Part 1: General Safety Requirements and Test Methods.” Ref. No. EN 13451-1.  
Adopted and published under various national designations by 25 member countries of CEN, including France, Great Britain, Germany, and Sweden.
7. 16 CFR Part 1213, “Safety Standard for Entrapment Hazards in Bunk Beds.”
8. 16 CFR Part 1513, “Requirements for Bunk Beds.”
9. U.S. Consumer Product Safety Commission. “Handbook for Public Playground Safety.” Publication No. 325.  
Public domain document, available at [www.cpsc.gov](http://www.cpsc.gov)

## APPENDIX D Anthropometric References

### Anthropometric References used:

Hall, Judith. **Handbook of normal physical measurements**. New York: Oxford University Press, 1990.

[Note: Head width and neck circumference data for both sexes, -2SD (2.5th percentile), from birth to age 16. Data visually extrapolated from graphs.]

Jurgens, H., Pieper, U. **International data on anthropometry**. Geneva, Switzerland: International Labour Office, 1990. (Occupational safety and health series; no. 65).

[Note: This report reviewed data for North America, Latin America (Indian population), Latin America (European and Negroid population, Northern Europe, Central Europe, Eastern Europe, South-Eastern Europe, France, Iberian Peninsula, North Africa, West Africa, South-Eastern Africa, Near East, North India, South India, North Asia, South China, South-East Asia, Australia (European Population), Japan.]

Peebles, Laura, Norris, Beverly J. **Adult data - The handbook of adult anthropometric and strength measurements: data for design safety**. London: Department of Trade and Industry, 1998.

[Note: This handbook contains data from various sources for the following countries: UK, Brazil, France, Germany, Italy, Japan, Poland, Sri Lanka, Sweden, Netherlands, and USA. Data were not available from ALL these countries for EACH measurement.]

Smith, Stuart, Norris, Beverly, Peebles, Laura. **Older adult data – The handbook of measurements and capabilities of the older adult: data for design safety**. London: Department of Trade and Industry, 2000.

[Note: This handbook contains data from various sources for the following countries: UK, Brazil, France, Germany, Italy, Japan, Poland, Sri Lanka, Sweden, Netherlands, and USA. Data were not available from ALL these countries for EACH measurement.]

Snyder, JRG. **Anthropometry of infants, children and youths to age 18 for product safety design: final report**. Bethesda, MD: Consumer Product Safety Commission, 1977.

### Others references consulted:

Association for the Advancement of Medical Instrumentation. **Human factors engineering guidelines and preferred practices for the design of medical devices**. 2<sup>nd</sup> ed. Arlington, VA: Association for the Advancement of Medical Instrumentation, 1993; AAMI HE-48 1993.

British Standards Institution. **1987 Ergonomics – standards and guidelines for designers.** United Kingdom: British Standards Institution, 1987; document no. PP 7317.

Damon, Albert, Stoudt, Howard W., McFarland, Ross A. **The human body in equipment design.** Cambridge, MA: Harvard University Press, 1966.

Diffrient, Niels. **Humanscale one-two-three.** Cambridge, MA: MIT Press, 1974.

**Human engineering design data digest.** Washington, DC: U.S. Government Printing Office, 1975.

National Center for Health Statistics. **Weight, height, and selected body dimensions of adults, United States, 1960-62.** Hyattsville, MD: National Center for Health Statistics, 1980; DHHS publication no. (PHS) 80-1301. Vital and health statistics; series 11, no. 8.





Salvendy, Gavriel, ed. **Handbook of human factors.** New York: John Wiley & Sons, 1987.

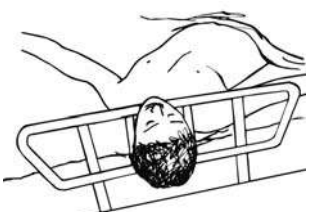

Woodson, Wesley E. **Human factors design handbook: information and guidelines for the design of systems, facilities, equipment and products for human use.** New York: McGraw-Hill Book Company, 1981.

Woodson, Wesley E., Conover, Donald W. **Human engineering guide for equipment designers.** 2<sup>nd</sup> ed. Berkeley, CA: University of California Press, 1970.

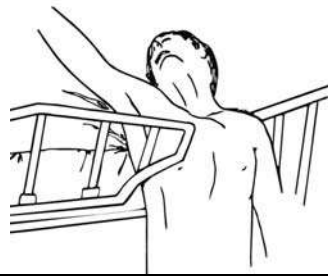
Woodson, Wesley E., Tillman, Peggy, Tillman, Barry. **Human factors design handbook.** 2<sup>nd</sup> ed. New York: McGraw-Hill Professional, 1992.

**APPENDIX E Drawings of Potential Entrapment in Hospital Beds**

<p><b>Zone 1 - Entrapment within the rail</b></p> 
<p><b>Zone 3 - Entrapment between the rail and the mattress</b></p> 
<p><b>Zone 5 - Entrapment between split bed rails</b></p> 
<p><b>Zone 7 - Entrapment between headboard or footboard and the mattress end</b></p> 

<p><b>Zone 2 - Entrapment under the rail, between the rail supports or next to a single rail support</b></p> 
<p><b>Zone 4 - Entrapment under the rail, at the end of the rail</b></p> 
<p><b>Zone 6 - Entrapment between the end of the rail and the side edge of the headboard or foot board</b></p> 

## **APPENDIX F Dimensional Test Methods for Bed Systems**



### **1. Introduction**

The Hospital Bed Safety Workgroup (HBSW) has defined seven numbered "zones" or spaces in and around hospital bed systems where patients could potentially become trapped. Actual entrapments have been reported in six of these zones, with Zones 1, 2, 3, and 4 accounting for approximately 72.5% and 80% of entrapment events reported respectively to Canada and to the FDA. This appendix contains instructions for testing Zones 1, 2, 3, and 4, using tools and methods developed by the HBSW.

### **2. Summary of Test Zones**

The four (4) tests in these instructions measure gaps within bed systems where a patient could become trapped. Each test measures a different area, or zone, where entrapment can occur:



**Zone 1: Within the rail:**

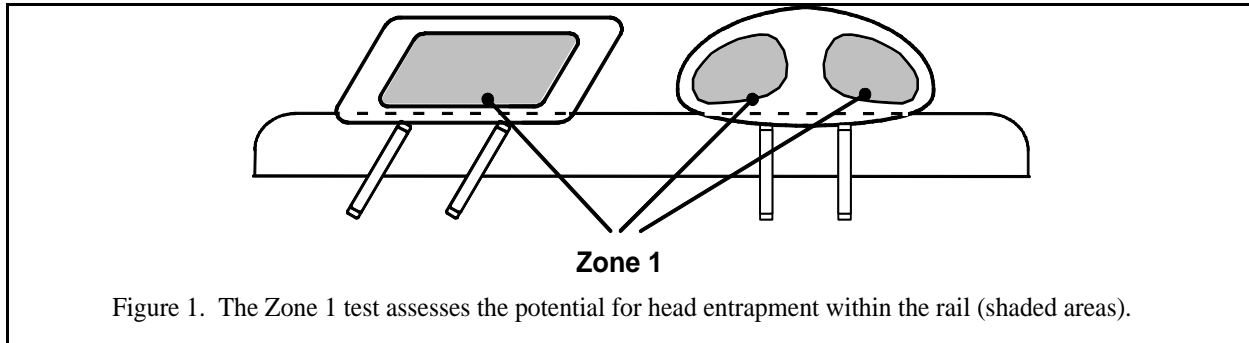

**Zone 2: Under the rail between the rail supports or next to a single support:**

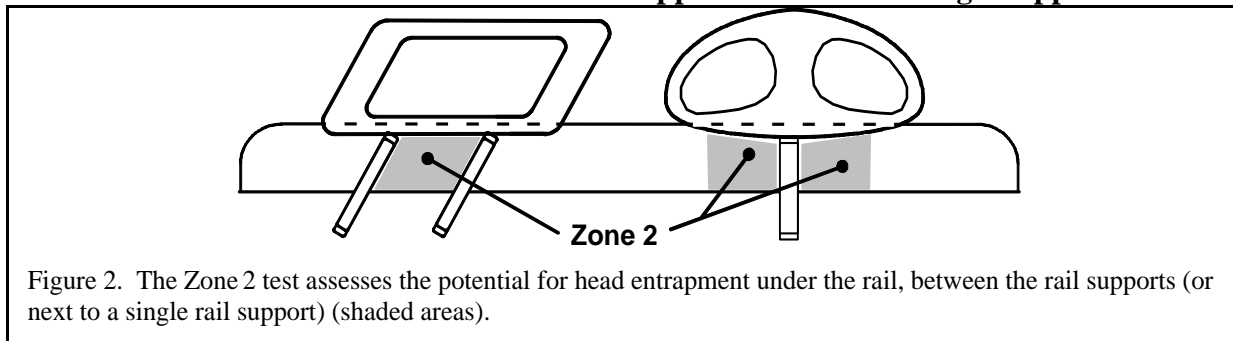

**Zone 3: Between the rail and the mattress:**

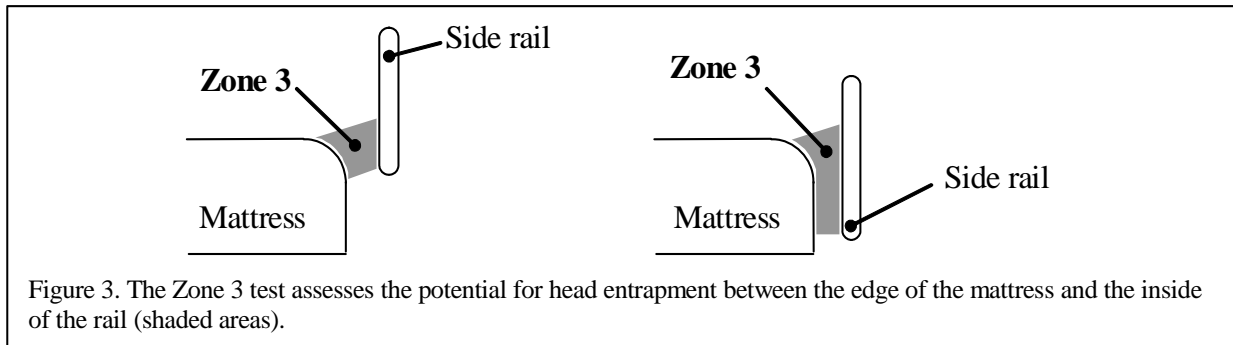

**Zone 4: Under the rail at the end of the rail:**

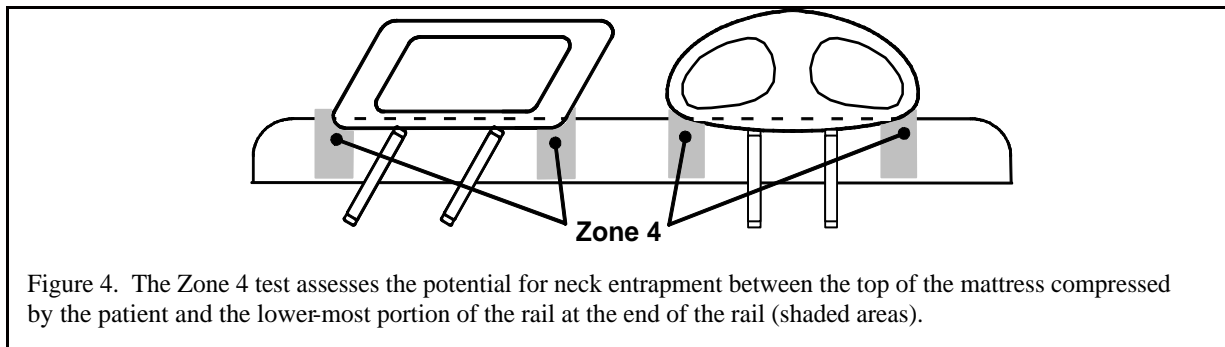

### 3 Description of Test Tools

Each test requires the use of simple tools, including a cone, a cylinder, and a spring scale. Tools used, if obtained from the source quoted above in Appendix B, may look slightly different from the tools in the figures, but they will work the same way.

#### 3.1 Cone and Cylinder Tool

The cone and cylinder is a combination tool (see Figure 5). It can be easily taken apart so that the cone and cylinder can be used separately. Tests 1, 2 and 3 use only the cone. Test 4 uses the combined assembled tool.



Figure 5: Cone and Cylinder Tool

- The diameter of the large end of the cone represents the width of a small adult head (120 mm, or approximately 4 ¾ inches).
- The diameter of the cylinder represents the size of a small adult neck (60 mm, or approximately 2 ⅜ inches).
- The cone and cylinder together weigh 66.7 N (15 lbs). This represents the combined weight of an adult head (53.4 N or 12 lbs.) and neck (13.3 N or 3 lbs.).
- The red area of the cylinder defines contact angles in which the neck could become wedged (60 degrees or narrower),

#### The cone tool includes the following features:

- A loop at the end for attaching a spring scale to measure applied forces.
- A safety strap to prevent the tool from falling on the tester's feet.
- A marked center line on the large face of the cone to help assess the depth of the cone in the Zone 3 test.

**The cylinder includes the following features:**

- Red and green zones for identifying pass/fail at siderail ends (Zone 4 test).
- A level to aid in tool positioning (Zone 4 test).

To prevent personal injury during the measurement process, attach the strap to a secure point on the bed and shorten the length of the safety strap enough to keep the tool from dropping on the tester's feet if it should fall during a test. Make sure the strap is long enough to not interfere with the test measurement.

**3.2 Tool Assembly and Disassembly**

**Note:** General procedures for tools with a screw-type connection are described here. (Some tools may have a different type of connection.) Follow the instructions supplied with the tools for more detailed information.

**To take the cone and cylinder tool apart:**

1. Turn the knob to loosen and remove the connection shaft.
2. Pull the cylinder from the cone.

**To put the cone and cylinder tool together:**

1. Align the red and green areas of the cone and cylinder.
2. Insert the pins of the cone into the cylinder.
3. Insert the connection shaft and turn the knob to tighten.



Figure 6: Disassembly and assembly of the cone and cylinder tool

### 3.3 Using the spring scale

Use the spring scale to apply 12 lbs (53.4 N) of force to the cone when testing Zones 1 and 2. At the small end of the cone tool, insert the scale hook into the metal loop. Pull the scale slowly until the needle points to 12 lbs (53.4 N).



Figure 7: Use of Spring Scale

For other types of scales (sliders, digital, etc.), and for information on scale calibration, consult the instructions supplied with the tool kit.

## 4. General Testing Considerations

- *Bed Occupancy:* For ease of mattress movement and measurement, and general safety, the patient should not be in the bed during the measurement procedures.
- *Bed Height:* To avoid unnecessary bending or back strain, position the bed at a comfortable working height.
- *Bed Wheels:* To prevent movement of the bed during testing, lock the wheels.
- *Linens/Sheets:* Perform the tests with sheets in place as is typical for patient care. Remove any pillows and blankets.
- *Infection Control:* To avoid cross-contamination, disinfect the tools each time a different bed is measured. Follow the supplier's recommendations for tool disinfection.
- *Personal Safety:* To avoid injury, use care when pulling the tool through openings in the bed rails. If the tool suddenly pulls through, you could lose your balance and fall. Always use the safety strap to keep the tool from injuring your feet if it falls.
- *Intermediate Rail Position:* Some rails have an intermediate stopping position or a high and low locking position. Follow the individual test instructions, which may require testing the rails at both positions.

- **Bed Position:** Most tests should be done with the bed in the flat position. The exception is the test for Zone 2. Follow the individual test instructions carefully.
- **Testing Tips:** Consult the Appendix for helpful information.
- **Type of Rails to Test:** Any type of rail attached to a bed should be assessed for entrapment risks. Full-length rails should be tested in the same manner as any other type of rail. Note that some full-length rails can present an entrapment risk when the bed is articulated (e.g., head elevated, knees raised), thus testing full-length rails in articulated bed positions is particularly important.

## 5. Test Methods

### 5.1 Zone 1 Test

***This test assesses the potential for head entrapment within the perimeter of the rail.***

The tools needed to do this test are the cone, the safety strap and the spring scale.

#### **Prepare for the Zone 1 Test:**

1. Lock the bed's wheels.
2. Put the bed in the flat, horizontal position.
3. Fully raise all bed rails.
4. Position the bed at a comfortable working height.

#### **Do the Zone 1 Test:**

1. With the cone resting on the mattress, attach the safety strap of the cone to the rail being tested. *Make sure the strap is short enough to keep the tool from injuring your feet if it falls, and long enough so it does not interfere with the test.*
2. From inside the rail, insert the cone, small end first, into the largest opening in the rail. Try to pull the tool through the space (see Figure 8).
3. If the tool **does not** pull through freely, attach the spring scale to the loop on the small end of the cone. Try to pull the cone through the rail by pulling on the attached spring scale using 12 lbs. (53.4 N) of force. *Use care when pulling. If the tool suddenly pulls through the*

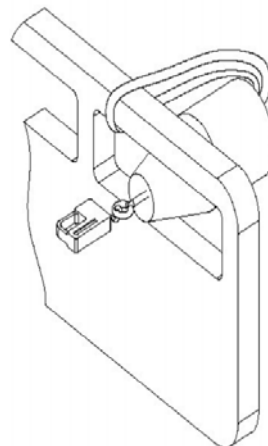

Figure 8: Zone 1 test  
(within the rail)

*opening, you may lose your balance and fall, or the tool may fall on you.*

4. Repeat steps 2 and 3 to check all other openings within the same rail.
5. Interpret test results.

### **Interpret the Zone 1 Results:**

If the large end of the cone **does not** enter any of the openings, this space **passes** the test (see Figure 9a).

If the large end of the cone **does** enter or pass through any of the openings, this space **fails** the test (see Figure 9b).

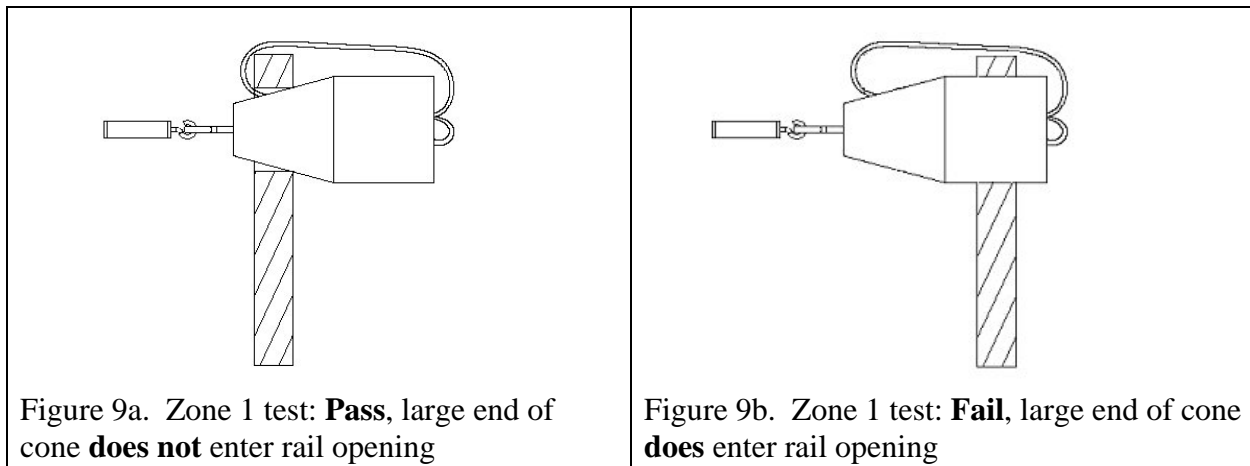

### **Repeat the Zone 1 Test:**

*On the other rails:* Repeat the test for all other rails on the bed; do not assume that the openings will all be the same.

## **5.2 Zone 2 Test**

***This test assesses the potential for head entrapment under the rail, at a location between the rail supports or next to a single support.***

The tools needed to do this test are the cone, the safety strap and the spring scale.

### Prepare for the Zone 2 Test:

1. Lock the bed's wheels.
2. Fully raise all bed rails.
3. Position the bed at a comfortable working height.

### Do the Zone 2 Test:

1. Firmly push the mattress away from the rail being measured until it stops.
2. Identify the space where the test will be done (see Figure(s) 10a and 10b).
3. Determine whether the bed will be tested in the flat position or a different position:

- Raise and lower the head and foot sections of the bed while you observe the space that will be tested.
- If the space(s) where the test will be done becomes smaller or does not change as the bed moves, do the test with the bed in the flat position (see the Appendix to the Test Methods for examples.)
- If the space(s) becomes larger as the bed moves, find the bed position that creates the largest space. Perform the test with the bed in the position where the space is the largest (see the Appendix to the Test Methods for an example.)

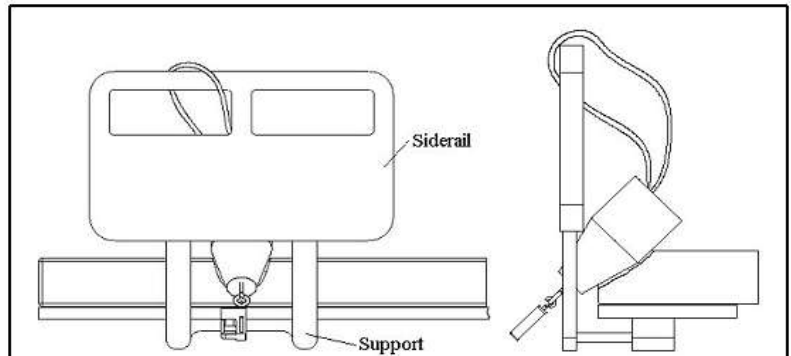

Figure 10a. Zone 2 test between rail supports.

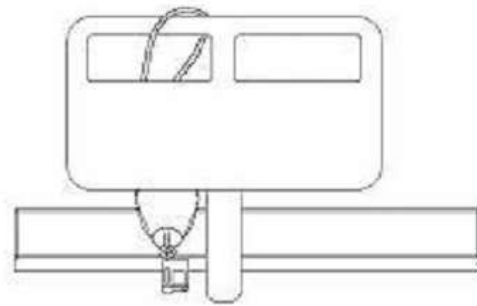

Figure 10b. Zone 2 test for a single rail support.

4. Attach the safety strap of the cone to the rail being tested. Make sure the strap is short enough to keep the tool from injuring your feet if it falls, and long enough so it does not interfere with the test.
5. From the inside of the rail, insert the cone, small end first, into the gap between the mattress and the lower edge of the rail, between the rail supports. Let the cone compress the mattress. Do not force the cone into the area.
6. Attach the spring scale to the loop on the cone.
7. Pull on the spring scale with 12 lbs (53.4 N) of force at any angle that increases the chances of the cone going through the space. Use care when pulling. If the tool suddenly pulls through the opening, you may lose your balance and fall, or the tool may fall on you. Observe whether the large end of the cone enters through the opening.
8. Interpret test results.

### Interpret Zone 2 Test Results:

If the large end of the cone **does not** enter the space under the rail, or pass under the rail, this space **passes** the test (see Figures 11a and 11b).

If the large end of the cone **does** enter the space under the rail, or if it passes under the rail, this space **fails** the test (see Figures 11c and 11d).

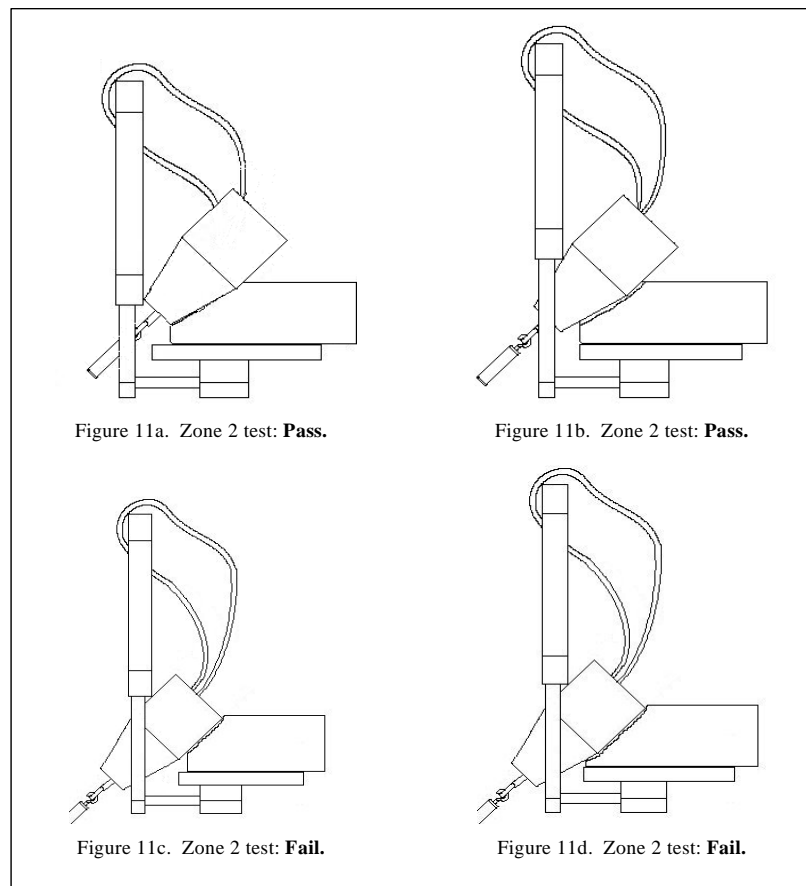



### Repeat the Zone 2 Test:

*On the same rail:* If the rail has intermediate locking positions, perform the test for every intermediate position.

*On the other rails:* Perform the test for all other rails on the bed, including intermediate and raised positions; do not assume that the openings will all be the same.

### 5.3 Zone 3 Test

*This test assesses the potential for head entrapment between the inside of the rail and the surface of the mattress (compressed by the weight of a patient's head) or edge of the mattress.*

The tools needed for this test are the cone and the safety strap.

#### Prepare for the Zone 3 Test:

1. Lock the bed's wheels.
2. Put the bed in the flat, horizontal position.
3. Fully raise all bed rails.
4. Position the bed at a comfortable working height.

#### Do the Zone 3 Test:

1. Firmly push the mattress away from the rail being measured until it stops.
2. Put the cone near the rail being tested and attach the safety strap. *Make sure the strap is short enough to prevent the tool from injuring your feet if it falls, and long enough so it does not interfere with the test.*
3. Gently place the cone horizontally in the gap (see Figure 12a). **Do not** push the tool down into the gap.
4. Turn the cone until the line on the face of the large end is horizontal (see Figure 12b).
5. Let the cone sink into the space by its own weight. If the cone is tilted, use one hand to gently level it (see Figure 12c). **Do not** push the tool down into the gap.

**NOTE:** If a mattress stop, rail support, or other structure keeps the cone from sinking in the gap, put the cone tool at a different location along the rail where there is no interference.

6. Determine whether the cone's center line is above or below the surface of the mattress.
7. Interpret test results.

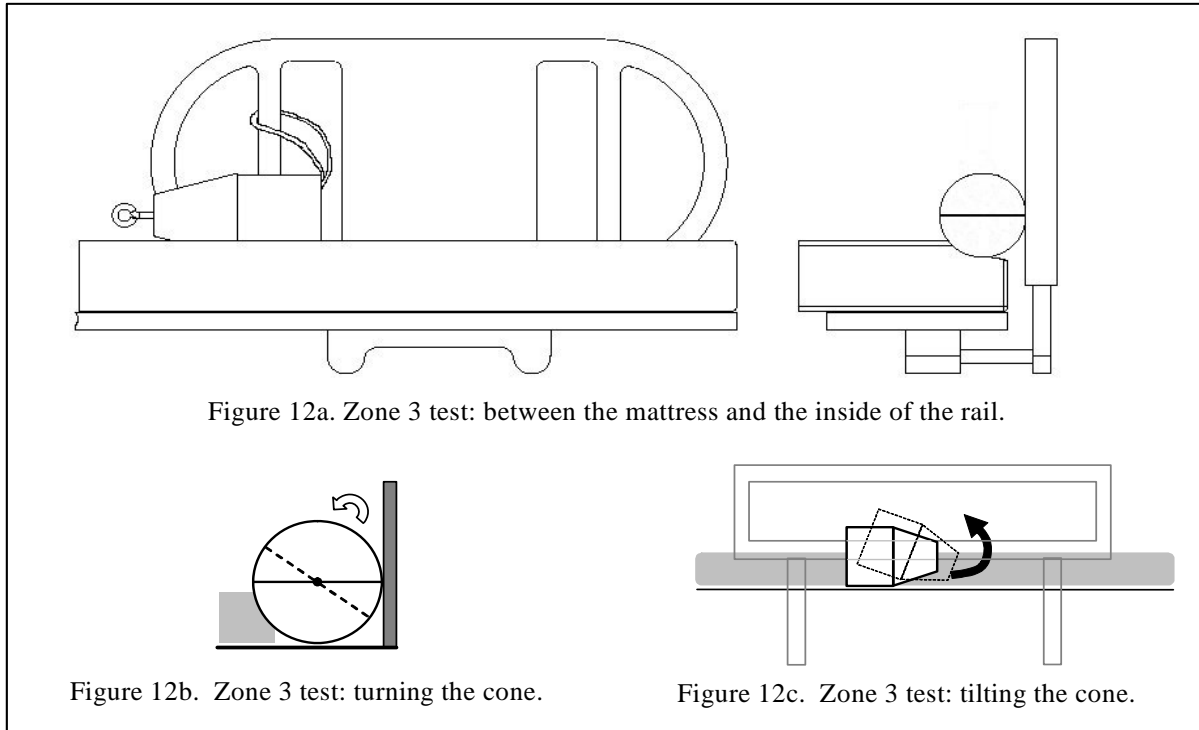

### Interpret Zone 3 Test Results:

If the line across the flat end of the cone is **above** the surface of the mattress, the space **passes** the test (see Figure 13a).

If the line across the flat end of the cone is **at or below** the top surface of the mattress, the space **fails** the test (see Figure 13b).

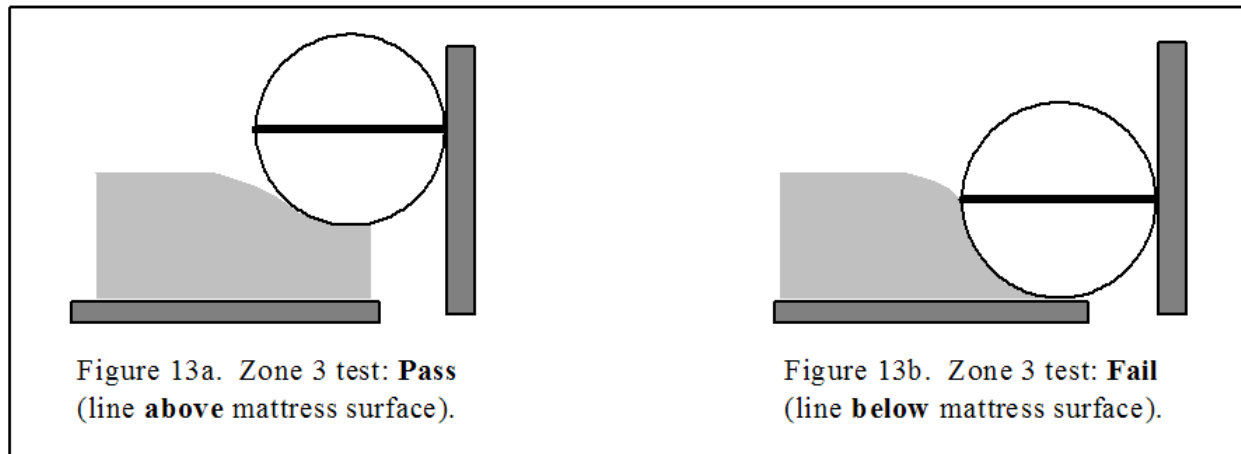

### Repeat the Zone 3 Test:

*On the same rail:* If the rail has any intermediate positions, perform the test at every intermediate position.

*On the other rails:* Perform the test for all other rails on the bed, including the intermediate positions; do not assume that the openings will all be the same.

## 5.4 Zone 4 Test

*This test assesses the potential for neck entrapment between the top of the mattress (compressed by the patient) and the lower-most portion of the rail, at the end of the rail.*

The tools needed for this test are the assembled cone and cylinder with safety strap.

### Prepare for the Zone 4 Test:

1. Lock the bed's wheels.
2. Put the bed in the flat, horizontal position.
3. Fully raise all bed rails.
4. Position the bed at a comfortable working height.

### Do the Zone 4 Test:

1. Firmly push the mattress away from the rail being tested until it stops.
2. Attach the safety strap of the cone tool to the rail being tested. *Make sure the strap is short enough to prevent the tool from injuring your feet if it falls, and long enough so it does not interfere with the test.*

3. Just beyond the end of the rail, rest the cone portion of the cone and cylinder tool on the mattress. The test area is shown in Figure 14. (If the bed has split rails, you may need to lower the rail next to the one being measured to make room for the tools.)

**Note:** If the cylinder tool **cannot fit** into an area between the head or footboard and the end of a rail, and if the large end of the cone does not enter or pass through the space below the rail defined by the end of the rail, the headboard (or footboard) and the

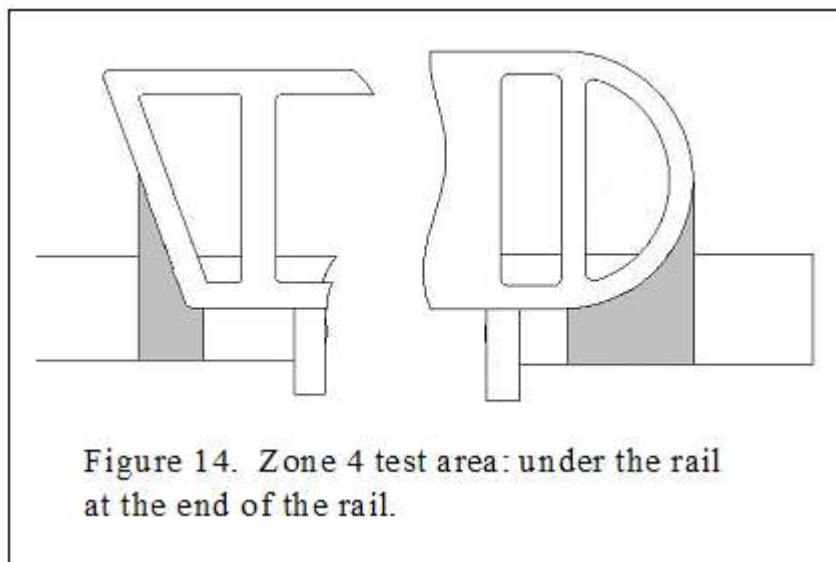

mattress, the space **passes** since the patient cannot in these circumstances place his neck between the lower portion of the rail at the end of the rail and the top surface of the mattress.

4. Position the tool so that the large face of the cone is flush or even with the edge of the mattress (see Figure 15a).
5. Let the weight of the cone compress the mattress, but do not force the tool down onto the mattress or under the rail. Slide the tool towards the rail until it touches the rail or support (see Figure 15b).

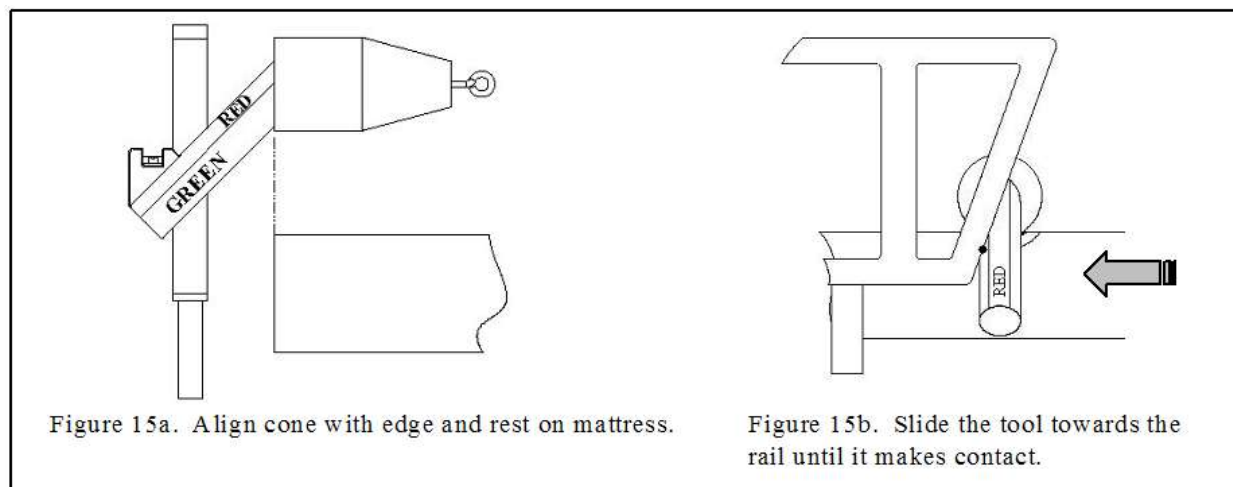

Figure 15a. Align cone with edge and rest on mattress.

Figure 15b. Slide the tool towards the rail until it makes contact.

6. Hold the cylinder section and use the level on the end of the cylinder to keep the cone level.
7. If the cylinder slides completely **under** the rail, this space **fails**. If the cylinder touches the rail, observe the color on the cylinder where it makes contact: **Red fails**; **Green passes** (see Figure 16).
8. Interpret test results.

### Interpret Zone 4 Test Results:

If the cylinder touches the rail in the **green** area, the space **passes** (see Figure 16a).

If the cylinder touches the rail in the **red** area, the space **fails** (see Figure 16b).

If the cylinder passes completely **under** the rail, the space **fails** (see Figure 16c).

Reminder: If the cylinder tool **cannot fit** into an area between the headboard or footboard and the end of a rail and if the large end of the cone does not enter or pass through the space below the rail defined by the end of the rail, the headboard (or footboard) and the mattress, the space **passes**.

### Repeat the Zone 4 Test:

*On the same rail:* If the rail has any intermediate positions, perform the test at every intermediate position.

*On the other rails:* Perform the Zone 4 test at both ends of all other rails on the bed, including the intermediate positions; do not assume that the openings will all be the same.

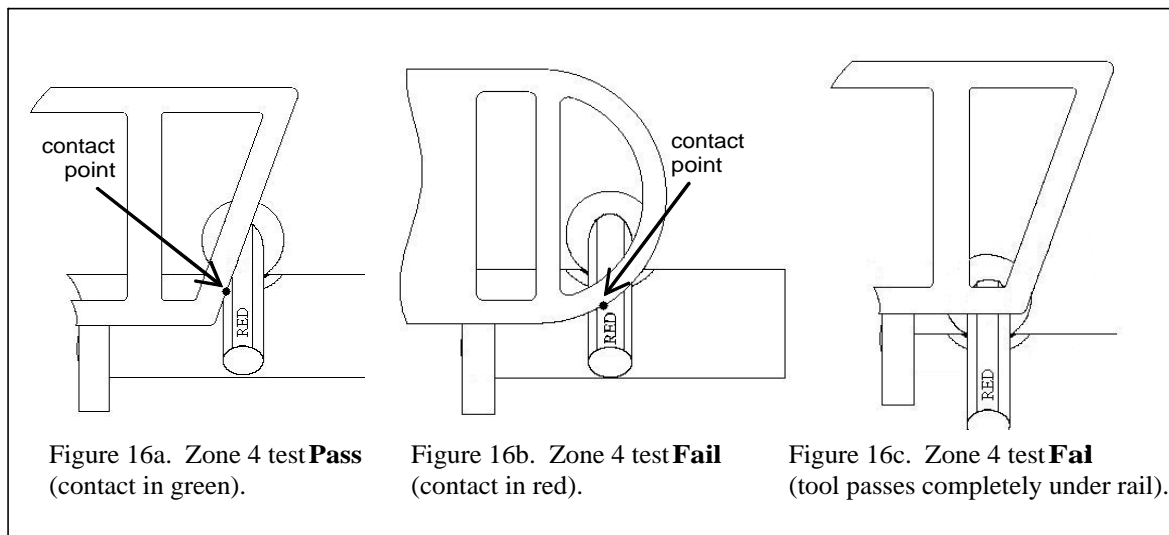

## **Appendix to HBSW Dimensional Test Methods for Bed Systems Testing Tips and Frequent Questions**

### ***Do I have to do the tests in order?***

No. You may do the tests in any order you wish. You may find it convenient to do all the tests on one side of the bed, then the other (to keep from repeatedly pushing the mattress back and forth and walking around the bed). Or, you may wish to do all of the tests that use just the cone, then all of the tests that use the cone and cylinder together (to avoid having to put the tool together and take it apart several times).

### ***Do I have to use the safety strap?***

The test tools are heavy, and the safety strap helps protect you if they fall or suddenly pull through a gap. Not using the safety strap increases the risk of injury.

### ***How do I keep track of my test results?***

You may use any method that meets your recordkeeping requirements. HBSW has developed some sample data sheets that you may use or modify according to your needs. Sample data sheets are attached at the end of this document.

### ***What are the most common mistakes people make when doing the tests?***

In field tests conducted to evaluate the test tools and instructions, some of the most common errors made by the testers were:

- Not pushing the mattress away from the test location;
- Pulling the mattress *toward* the test location (instead of pushing it *away*);
- Not articulating the bed enough to create the largest possible gap in Zone 2;
- Not having the bed flat when testing Zones 1, 3, or 4;
- Not aligning or leveling the tool properly; and
- Forcibly pushing the tool into gaps.

### ***When pushing the mattress, how hard do I need to push?***

Some test instructions ask you to push the mattress "until it stops." Usually that means pushing until either:

- the mattress retention system (such as mattress stops, straps, or Velcro<sup>®</sup>) engages and keeps you from pushing the mattress any further, or
- the mattress stops against the opposite side rail(s).

Always make sure you push the mattress straight across; it should not be crooked on the bed.

### When testing Zone 2, what position should the bed be in?

Unlike the other three tests, the Zone 2 test is not always done with the bed in the flat position. Before you do the Zone 2 test, you first need to find the correct testing position. With the bed in the flat position, identify the location of the Zone 2 space. Then, articulate the bed (adjust the head and knee sections) while you watch the Zone 2 space. As you articulate the bed, the Zone 2 space may get bigger, get smaller, or stay the same. Adjust the position of the bed until you find the position that makes the **largest** opening in Zone 2. If the size of the opening gets smaller, or does not change, return the bed to the flat position to do the test. Some examples of how Zone 2 might change with articulation are shown below.

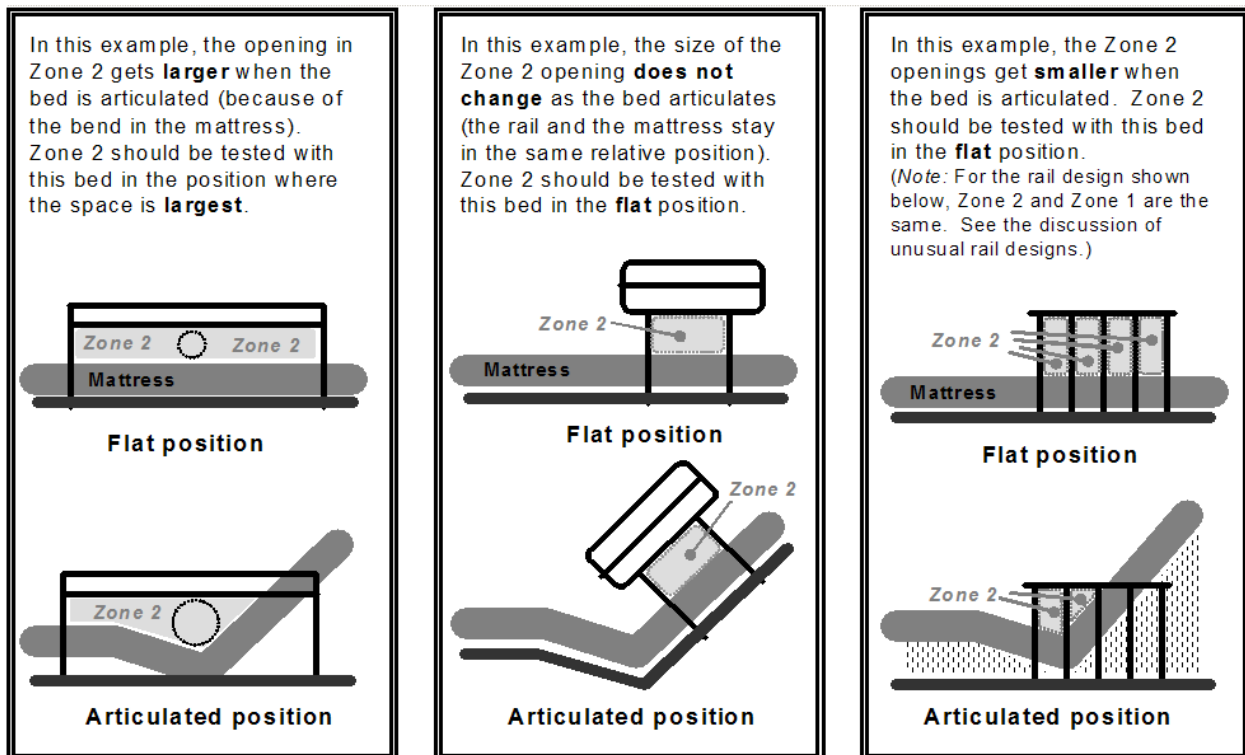

### What if one of the Zones doesn't seem to exist on a particular bed system?

If a zone doesn't exist on a particular bed, then there is no risk of a patient becoming trapped in that Zone. For example: if there are no openings in a rail, then a patient could not get his or her head trapped in Zone 1 of that rail. If you are using a generic form (such as a table or spreadsheet), it may be appropriate to record a result of either "pass," "not applicable," or "not tested," or to cross out entry spaces for Zones that do not exist. (You should provide some indication that the Zone was not accidentally omitted from testing.)

***I need to test a bed with an unusual rail design. The rails don't look like any of the rails shown in the instructions or video. How do I figure out where to do each test?***

Occasionally, the most difficult part of a test may be figuring out where on the bed to perform the test. For some beds or rail configurations, it may be difficult to identify the locations of various Zones. The following hints and examples for each Zone may help.

**Zone 1:** The goal of the Zone 1 test is to see whether a patient could become trapped by putting his or her **head through** an opening in the rail itself.

**Example: No openings in the rail**

If there are no openings in the rail, then there is no risk of entrapment in Zone 1. Examples of cases where there may not be any openings in the rail are:

- The rail consists of a solid panel; or
- The rail has a cover on it, and the cover blocks all the openings in the rail (whether you can see through the cover or not).

**Zone 2:** The goal of the Zone 2 test is to see whether a patient could become trapped by putting his or her **head under** the rail, head first, between the rail supports (or next to a single support). (Note: Trapping the head by sliding the neck under the rail sideways is addressed by the test for Zone 4.)

**Example: Rail supports form part of the rail**

In some designs, the rail supports also form part of the body of the rail. Crib-style rails, shown here, are common examples. Often, when the rail supports form part of the rail, Zones 1 and 2 overlap. Zone 1 should be tested with the bed in the flat position; if the size of the space changes with articulation, the result for Zone 2 may be different.

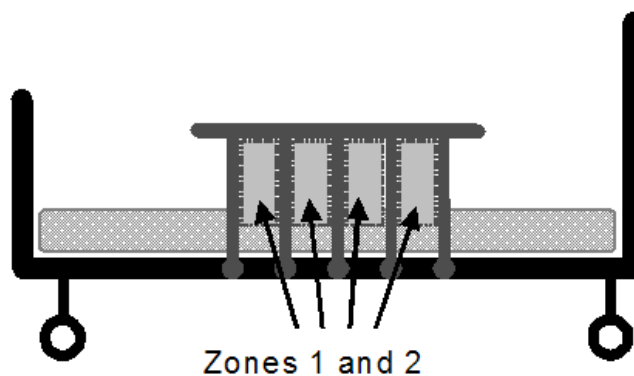



**Zone 3:** The goal of the Zone 3 test is to see whether a patient could become trapped with his or her **head in the horizontal space between** the rail and the mattress. Usually, the gap in Zone 3 is easily identified, even if the rail design is unusual.

**Zone 4:** The goal of the Zone 4 test is to see whether a patient could become trapped by sliding or wedging his or her **neck under** the end of the rail.

**Example: The rail end is very close to headboard or foot board (very little space in between)**

When testing in Zone 4, do not try to force the cylinder down between the rail and the end board or insert it under the rail from behind. If the cylinder's diameter will not fit between the end of the rail and the headboard or footboard, and if the large end of the cone cannot pass through the space under the rail delimited by the board, mattress and rail, then record a result of Pass for Zone 4.

**Note:** Testing with the large end of the cone is necessary to prevent the possibility that, despite the space above between the rail's end and the board being too small for a neck to enter from above, the neck might enter Zone 4 if the head can first pass through the area below the rail that is bordered by the mattress, rail and board.

**Example: Full-length rail with horizontal supports at the ends**

An example of this rail type is shown at the right. The cylinder cannot pass between the end of the rail and the headboard or footboard and then under the rail -- it would stop on the support. As well, the head cannot enter the space between the rail, mattress and board at a location below the rail. The result for Zone 4 is Pass, because a patient would not be able to get his or her neck under the rail. The potential for head-first entrapment under the rail should be evaluated using the test for Zone 2.

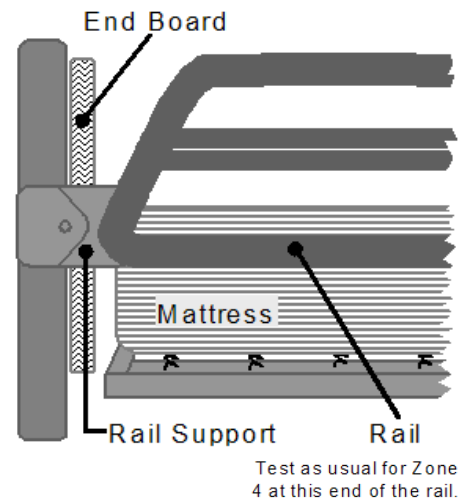

**Example: The end of the rail is vertical**

When the end of the rail is completely vertical from top to bottom, there may be no space "under" the end of the rail where the cylinder (or a patient's neck) could fit. In the example below, the left side of the rail is vertical, and there is no space "under" the end of the rail. For the left rail end in the figure, the rating for Zone 4 should be either "pass" or

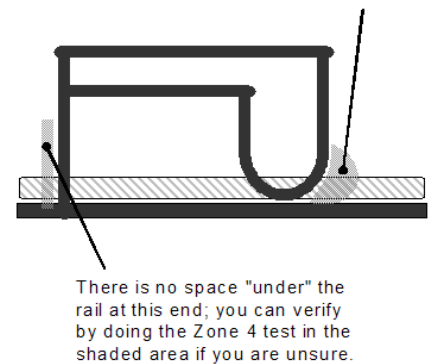

“not applicable”. The right end should be tested as usual for Zone 4.

**Note:** If you are unsure about a particular rail you are testing, you should go ahead and perform the Zone 4 test to verify your answer.

The cone and cylinder would give a result of Pass if they were used to physically test the area shown on the left side of the rail in the figure.

***Why did my colleague and I get different results for the same test?***

Different testers can get different test results for the same bed system. Or, the same tester may get a different result when he or she repeats a test. Some reasons this can happen are:

- Different people may handle the tools slightly differently.
- An error or oversight can affect the test result (see common errors above).
- When a test is a very close call, some testers may be biased toward passing, and others toward failing.
- A long time has elapsed between tests (mattresses vary in softness, and can compress over time; rails or rail supports may loosen or bend over time).

***What if a result is too close to call?***

If you are faced with a borderline pass/fail decision, use your best judgment to decide on a result. You can also try these suggestions:

- Repeat the test, and double-check that you did every step correctly.
- If possible, get a second opinion. Ask a colleague for help.

For beds with borderline passes that result from close calls, you may wish to consider mitigation (see the next question below).

***What should I do if a bed system fails one of the tests?***

You should strongly consider mitigation of entrapment risks for bed systems that fail any of the four tests. You may also wish to consider mitigation for bed systems that have borderline passes. Mitigation may include patient assessment; some patients are at lower risk for entrapment than others. For more information, consult the following, available as links from the U.S. FDA website:

- *Clinical Guidance for Assessment and Implementation of Bed Rails in Hospitals, Long Term Care Facilities and Home Care Settings*
- *A Guide for Modifying Bed Systems and Using Accessories to Reduce the Risk of Entrapment*

***What if I have a question that wasn't answered here?***

An advisory group has been established by the HBSW to address additional questions that arise. FAQs (Frequently Asked Questions) produced by this group are available as a link from the U.S. FDA website.

You may submit questions to that committee (cc Health Canada) or to Health Canada directly.

### Sample Datasheets

